

P1 SHORTING_PLUG Place jumper pos. 1-2 for 12V backlight voltage (default)
 Place jumper pos. 2-3 for 5V backlight voltage

P2 SHORTING_PLUG Place jumper pos. 1-2 for 5V digital voltage
 Place jumper pos. 2-3 for 3.3V digital voltage (default)

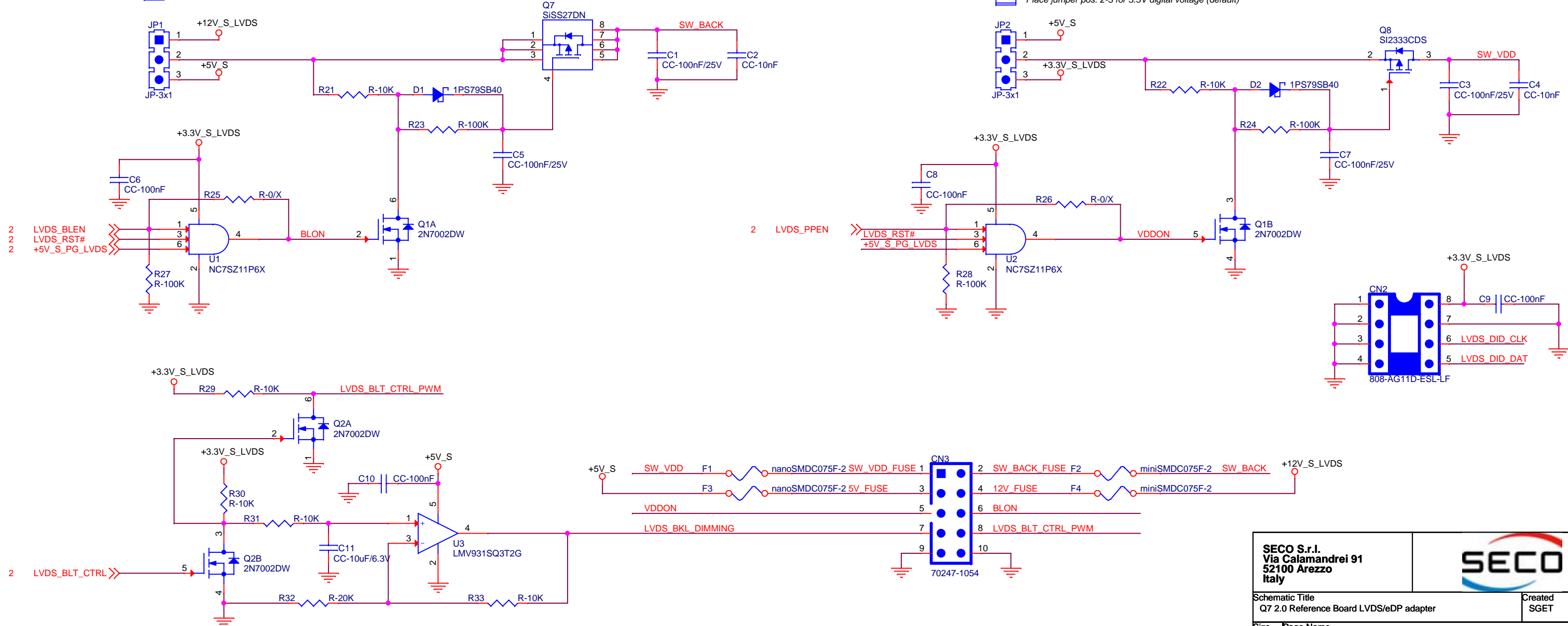

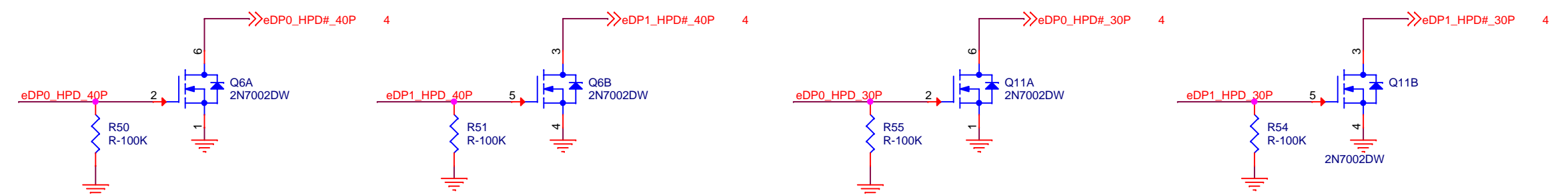
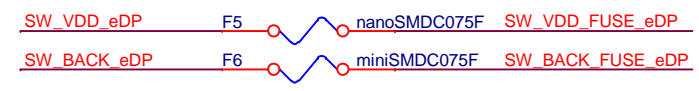
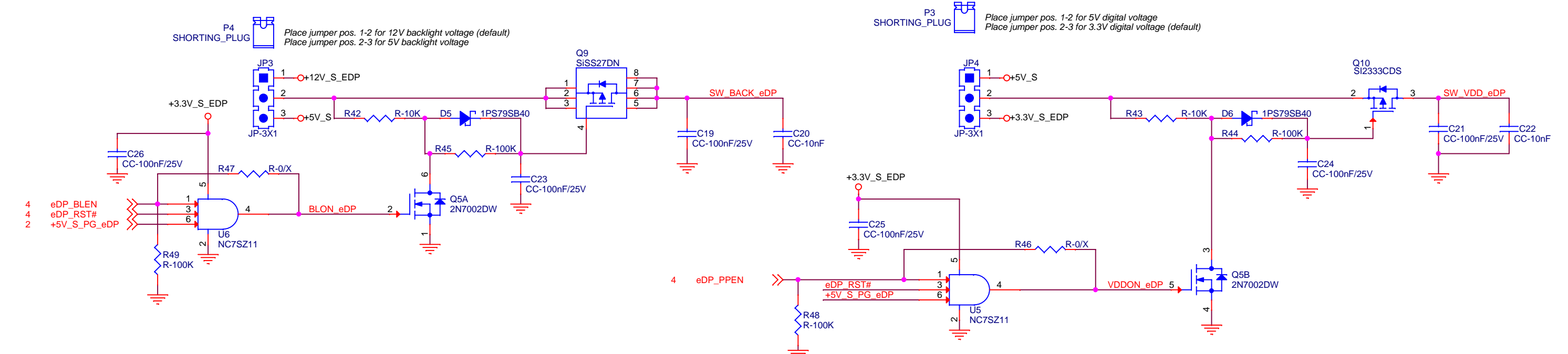
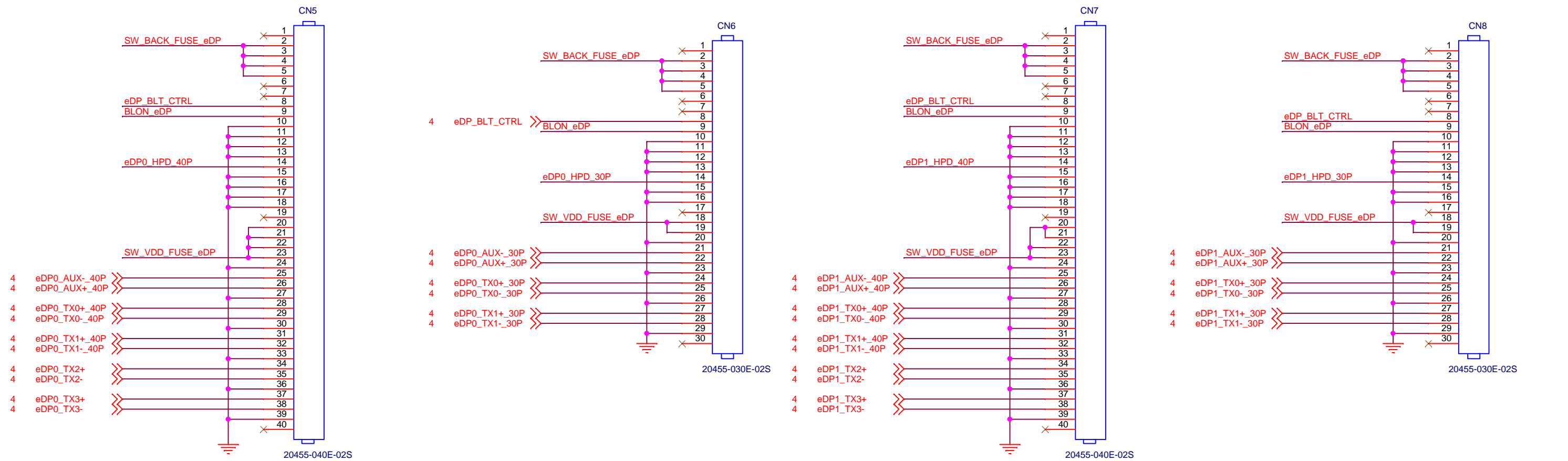

SECO S.r.l. Via Calamandrei 91 52100 Arezzo Italy		
Schematic Title Q7 2.0 Reference Board LVDS/eDP adapter		Created SGET
Size A3	Page Name eDP #1	Rev 1
Date: Wednesday, May 13, 2015		Sheet 3 of 4

