

# **SANTINO core**

Arm® Cortex®-A9 Single Board Computer

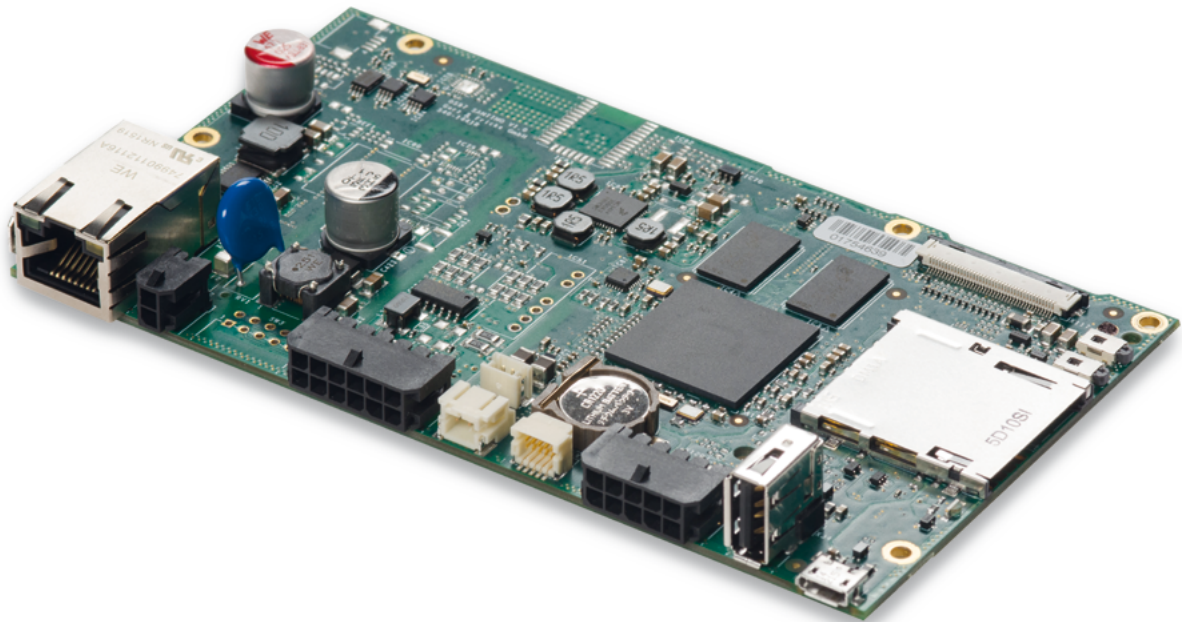

The i.MX6 economy solution for 7.0" TTL displays with industrial features.

## **Product Manual**

## Document Revision History

The information in this document is subject to change without prior notice in order to improve reliability, design and function and does not represent a commitment on the part of the manufacturer.

Revision	Date	Author	Description
V 1	09.03.2017	CG	Initial Release
V 2	15.03.2018	CG	Page 16 New Picture RS485 Pin 6 to 11
V 3	08.08.2019	CG	Page 26, new Picture (change Side of PIN Number)
V 4	26.08.2019	CG	Change Address
V 5	17.12.2021	bmy	SECO CI Update 2022

**Online support on [edge.seco.com](http://edge.seco.com)**

## Table of Contents

<b>1.</b>	<b>Introduction</b> .....	<b>4</b>
<b>2.</b>	<b>Safety Hints</b> .....	<b>5</b>
<b>3.</b>	<b>Product Introduction</b> .....	<b>6</b>
3.1	Type Plate and Device Information .....	6
3.2	Related Documents and Online Support.....	7
<b>4.</b>	<b>Technical Data</b> .....	<b>8</b>
4.1	Block Diagram SBC .....	9
4.2	Technical Drawing .....	10
4.3	Connectors.....	11
<b>5.</b>	<b>Installation and Start Up</b> .....	<b>13</b>
5.1	Connection Scheme .....	13
<b>6.</b>	<b>Internal and External Interfaces</b> .....	<b>14</b>
6.1	GND Shield Connector (X122).....	14
6.2	Ethernet (X118) .....	14
6.3	Power (X1).....	15
6.4	DIP Switch (SW3).....	15
6.5	CAN/RS-485 Interface (X39) .....	16
6.6	Speaker (X9).....	17
6.7	Keypad/SPI (X106).....	18
6.8	RS-232/RS-232 (X13).....	19
6.9	USB Host (X34) .....	20
6.10	USB OTG (X20) .....	20
6.11	SD Card Reader (X31) .....	20
6.12	Reset Switch (SW1) .....	21
6.13	Bootselect Switch (SW2) .....	21
6.14	Power LED (D30).....	21
6.15	Display Interface (X117).....	22
6.16	Resistive Touch (X4) .....	23
6.17	Battery-Holder (X2).....	24
6.18	Speaker Internal (X10) .....	25
6.19	Capacitive Touch (X16) .....	26
	Capacitive Touch (X116) * .....	27
	Capacitive Touch (X119) * .....	27
	Capacitive Touch (X120) * .....	27
	Capacitive Touch (X115) * .....	28
	Capacitive Touch (X114) * .....	28
<b>7.</b>	<b>Battery</b> .....	<b>29</b>
7.1	Battery Specifications.....	29
7.2	Replacement of the Internal Battery .....	30
<b>Annex A:</b>	<b>Hardware Revision Information</b> .....	<b>31</b>
<b>Annex B:</b>	<b>Assembly Options</b> .....	<b>32</b>
B-1	Wi-Fi / Bluetooth .....	32
<b>Annex C:</b>	<b>Guidelines and Standards</b> .....	<b>33</b>
C-1	RoHS Declaration.....	33
C-2	Supplier Declaration – Directive EG 1907/2006 REACH.....	33
C-3	UL Certification.....	33
C-4	SECO Northern Europe Conformity Statement.....	34
<b>Annex D:</b>	<b>Common Documentation</b> .....	<b>35</b>
D-1	Warranty Hints .....	35
D-2	Field of Application.....	36
<b>Annex E:</b>	<b>Technical Support</b> .....	<b>37</b>
<b>Annex F:</b>	<b>General Information</b> .....	<b>38</b>

\* alternative assembly upon request

## 1. Introduction

Thank you very much for purchasing a SECO Northern Europe product. Our products are dedicated to professional use and therefore we suppose extended technical knowledge and practice in working with such products.



The information in this manual is subject to technical changes, particularly as a result of continuous product upgrades. Thus this manual only reflects the technical status of the products at the time of printing. Before design-in the device into your or your customer's product, please verify that this document and the therein described specification is the latest revision and matches to the PCB version. We highly recommend contacting our technical sales team prior to any activity of that kind.

The attached documentation does not entail any guarantee on the part of SECO Northern Europe GmbH with respect to technical processes described in the manual or any product characteristics set out in the manual. We do not accept any liability for any printing errors or other inaccuracies in the manual unless it can be proven that we are aware of such errors or inaccuracies or that we are unaware of these as a result of gross negligence and SECO Northern Europe has failed to eliminate these errors or inaccuracies for this reason. SECO Northern Europe GmbH expressly informs that this manual only contains a general description of technical processes and instructions which may not be applicable in every individual case. In cases of doubt, please contact our technical sales team.

In no event, SECO Northern Europe is liable for any direct, indirect, special, incidental or consequential damages arising out of use or resulting from non-compliance of therein conditions and precautions, even if advised of the possibility of such damages.



Before using a device covered by this document, please carefully read

- ▶ **Annex „D-1 Warranty Hints“**
- ▶ **Annex „D-2 Field of Application“**



Embedded systems are complex and sensitive electronic products. Please act carefully and ensure that only qualified personnel will handle and use the device at the stage of development. In the event of damage to the device caused by failure to observe the hints in this manual and on the device (especially the safety instructions), SECO Northern Europe shall not be required to honour the warranty even during the warranty period and shall be exempted from the statutory accident liability obligation. Attempting to repair or modify the product also voids all warranty claims.

## 2. Safety Hints

Please read this section carefully and observe the instructions for your own safety and correct use of the device. Observe the warnings and instructions on the device and in the manual. SECO Northern Europe embedded systems have been built and tested by us and left the company in a perfectly safe condition. In order to maintain this condition and ensure safe operation, the user must observe the instructions and warnings contained in this manual.



### I. General Handling

- ▶ Don't drop or strike the unit: The PCB, display and/or other parts might be damaged.
- ▶ Keep away from water and other liquids, the unit is not protected against.
- ▶ Operate the unit under electrical and environmental conditions according to the technical specification.
- ▶ The electrical installations in the room must correspond to the requirements of the local (country-specific) regulations.
- ▶ Take care that there are no cables, particularly power cables, in areas where persons can trip over them.
- ▶ Do not place the device in direct sunlight, near heat sources or in a damp place.
- ▶ All plugs on the connection cables must be screwed or locked to the housing.
- ▶ Repairs may only be carried out by qualified specialist personnel authorized by SECO Northern Europe GmbH or their local distributors.
- ▶ Maintenance or repair on the open device may only be carried out by qualified personnel authorized by SECO Northern Europe GmbH which is aware of with the associated dangers.



### II. Electricity

- ▶ The embedded systems may only be opened in accordance with the description in this user's manual for
  - replacing of the (rechargeable, where applicable) lithium battery and/or
  - configuration of interfaces, where applicable
- ▶ These procedures have to be carried-out only by qualified specialist personnel.
- ▶ When accessing internal components the device must be switched off and disconnected from the power source.
- ▶ When purchased core or basic versions without protecting back cover, don't touch the PCB directly with your fingers. Especially these products need to be handled very carefully.
- ▶ Don't operate or handle the unit without typical ESD protection measures, such as ground earthing.
- ▶ Operate the unit according to the technical specification only.



### III. Damage or Permanent Malfunction

- ▶ It must be assumed that a safe operation is no longer possible, in case
  - the device has visible damage or
  - the display is dark or shows strange pattern for longer period
  - the device doesn't react after a reset
- ▶ In these cases the device must be shut down and secured against further use

### 3. Product Introduction

This document is applicable for hardware revisions 1.0 or later of the SANTINO series.

Please find the hardware version grid in „**Annex A: Hardware Revision Information**“:

SANTINO is an Embedded System to be used as human machine interface (HMI) in various applications. Please refer to **Annex „D-2 Field of Application“** for further information. The system is equipped with a large number of industrial interfaces. A wide variety of options is available as well.

#### 3.1 Type Plate and Device Information

For service and later identification of the device, the type plate contains important information.

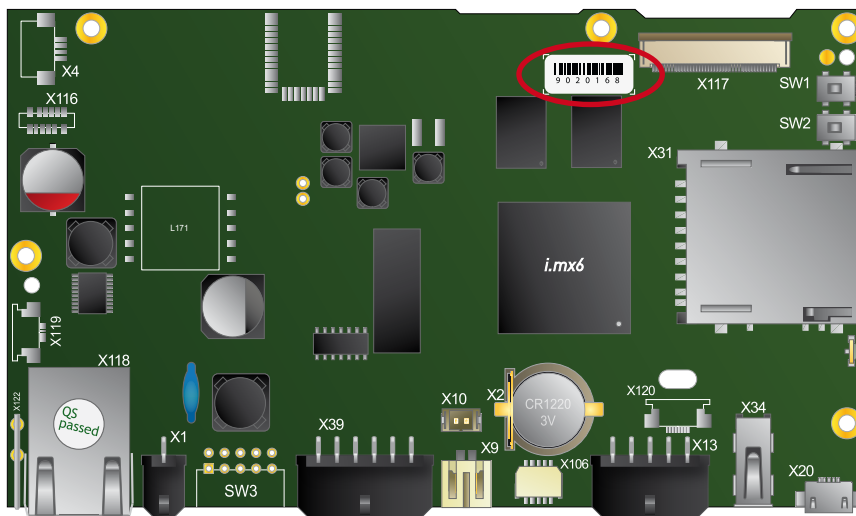



code defines the serial number



## 3.2 Related Documents and Online Support

This document contains operating system specific information. The following additional documentations are available:

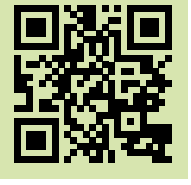
### OPERATING SYSTEMS

Linux Yocto Jethro	 <a href="https://bit.ly/3DjEihg">https://bit.ly/3DjEihg</a>	Contains information about Linux BSP with development environment Linux Embedded System Yocto (Codename: Jethro, Version 3.0) includes first information about the bootloader Flash-N-Go
Linux Yocto Rocko	 <a href="https://bit.ly/3xNQKvc">https://bit.ly/3xNQKvc</a>	
Android 7.1	 <a href="https://bit.ly/3de2N4H">https://bit.ly/3de2N4H</a>	

### UPDATE / BOOT / SYSTEM

Flash-N-Go	 <a href="https://bit.ly/3pmwWo4">https://bit.ly/3pmwWo4</a>	Contains information about the usage of the G&F Flash-N-Go solution which consists of three submodules: <ul style="list-style-type: none"> <li>▶ Flash-N-Go Boot (A tiny boot loader)</li> <li>▶ Flash-N-Go System (A maintenance os)</li> <li>▶ Flash-N-Go Update (A GUI based update solution for all os)</li> </ul>
------------	--	--

## 4. Technical Data

CPU	x1	x2L
CPU Type	i.MX6Solo	i.MX6DualLite
Core Class	Arm® Cortex®-A9	
Core Clock	1 GHz	
Features	NEON for SIMD media acceleration and VFP operations; Multi-format HD 1080p video decoder and HD 720p video encoder hardware engine; L1 cache, 32 KB for instruction, 32 KB for data; 512 KB L2 cache	
HW Accelerators	OpenGL ES 2.0, OpenVG 1.1	
RTC	Accuracy: +/- 30 ppm at 25°C	
<b>Memory</b>		
eMMC Flash	4 GB MLC eMMC	
RAM Standard	512 MB 32 bit DDR3L	1 GB 32 bit DDR3L
SD Card Slot	4 bit MMC/SDIO/SD/SDHC	
<b>Operating Systems</b>		
Supported OS	Windows Embedded Compact 7/2013, Linux Yocto, Android	
<b>Communication Interfaces</b>		
Network	1x 10/100 Mbit/s Ethernet (RJ-45)	
USB 2.0	1x 480 Mbit/s Host (Type A) 1x 480 Mbit/s OTG (Type Micro-AB) <sup>1</sup>	
CAN Fieldbus/ RS-485	1x CAN (ISO/DIS 11898) + 1x RS-485	1x CAN (ISO/DIS 11898) + 1x RS-485 galvanic isolated
RS-232	2x RS-232 (RX/TX/CTS/RTS) MDB <sup>2</sup> / 1x MDB (Master / Slave optional) <sup>3</sup> instead of 2nd external RS-232	
Synchronous Serial Interfaces	I <sup>2</sup> C, Matrix keypad up to 4 x 4	
<b>Audio</b>		
Speaker output	1x speaker (connector), 1.5 W RMS (8Ω)	
Audio Internal	1x speaker connector parallel to external output	
<b>Display and Touch</b>		
Display Interface	TTL, 18 bit (RGB)	
Touch Interface	4-wire analog resistive; PCAP I <sup>2</sup> C	
<b>Device Dimensions</b>		
W x H x D	138.0 x 18.0 x 80.0 mm	
Weight	97g	
<b>Power Supply</b>		
Supply Voltage	Nom. 9 to 32 V DC	
Consumption	Typ. 2.0; max. 19.6 W	
Internal Backup Battery (RTC)	Type: 3 V Lithium battery Type CR1220: Lifetime (RTC only): Approximately 8 years, depending on application	
<b>Typical Environmental Conditions</b>		
Storage Temp.	-20 to +70 °C	
Operating Temp.	0 to +60 °C	
Humidity	5 to 90 % RH	
Max. Operating Altitude ty	3.000 m	
Max. Storage/Transit Altitude	10.000 m	
Noise Level [db(A)] @ 1m	<<40 (fanless design)	
<b>Lifetime</b>		
MTBF	≥ 400.000 h	

<sup>1</sup> Mechanically the Micro-USB interface has not been designed for frequent contact operations. Please use an adapter cable with a strain relief.

<sup>2</sup> Option

<sup>3</sup> The selection of a variant eliminates the other.



## 4.1 Block Diagram SBC

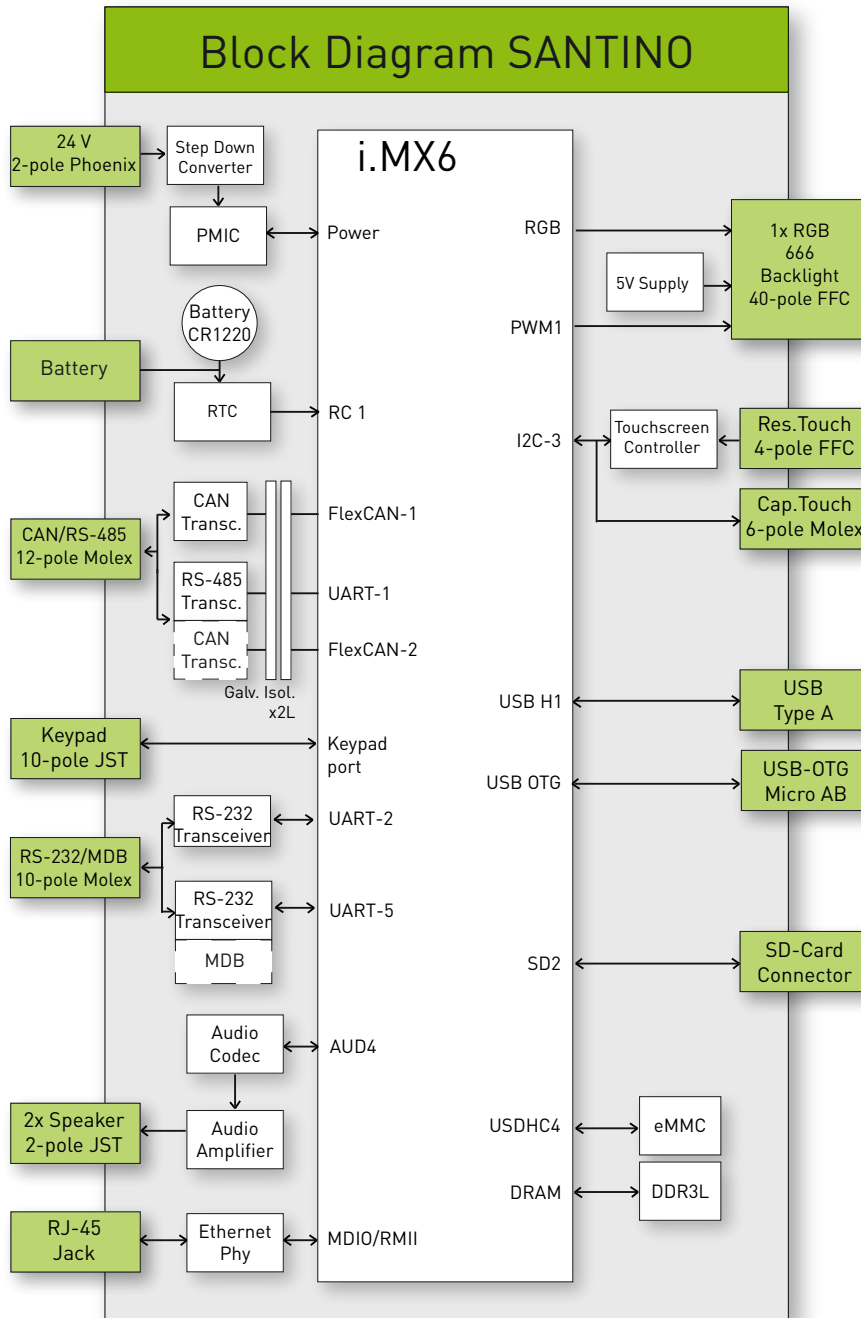

## 4.2 Technical Drawing

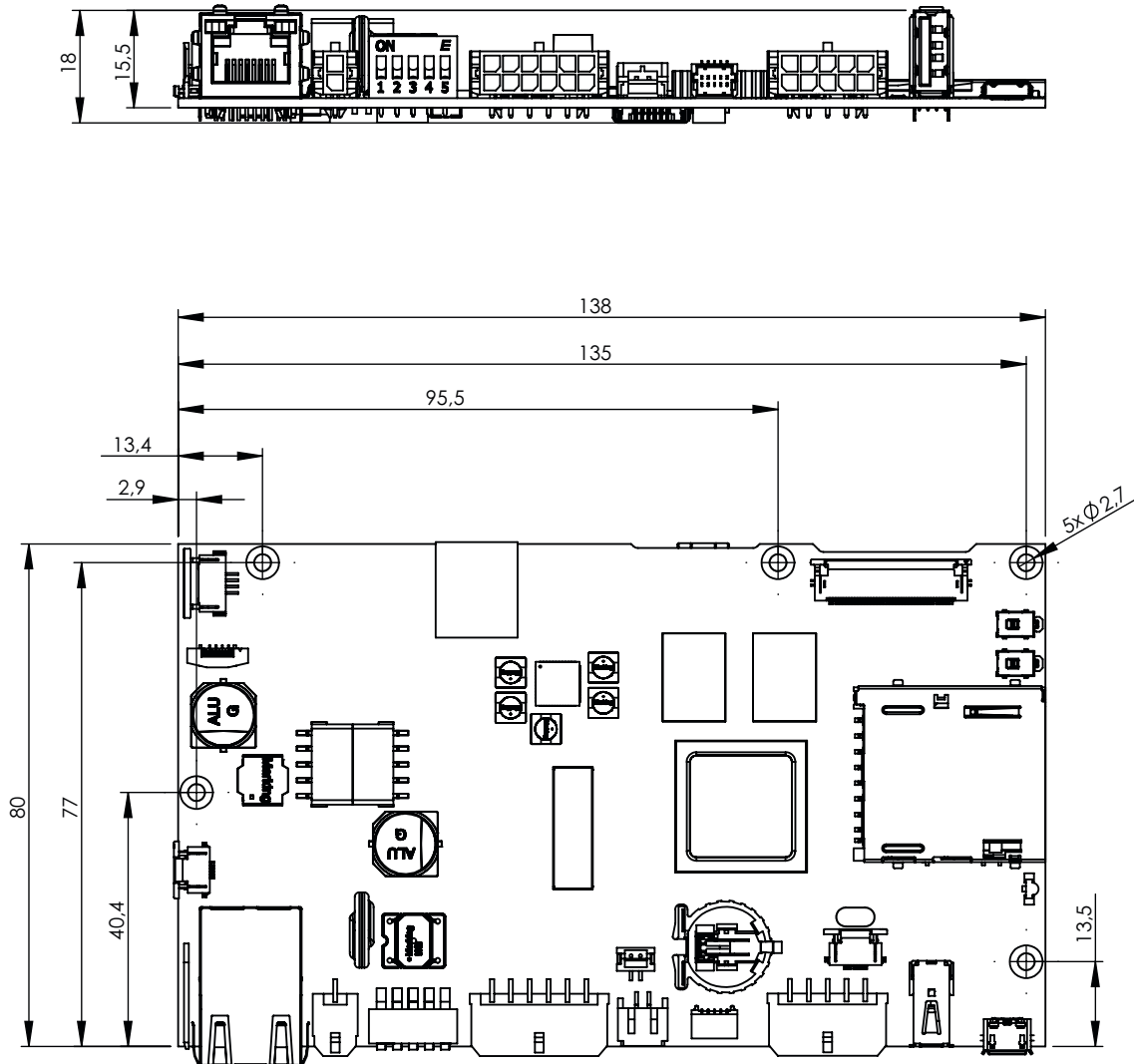

Missing dimensions according to 3D CAD files

### 4.3 Connectors

As this manual describes a core version, the internal and external interfaces will be mentioned in the following chapter.

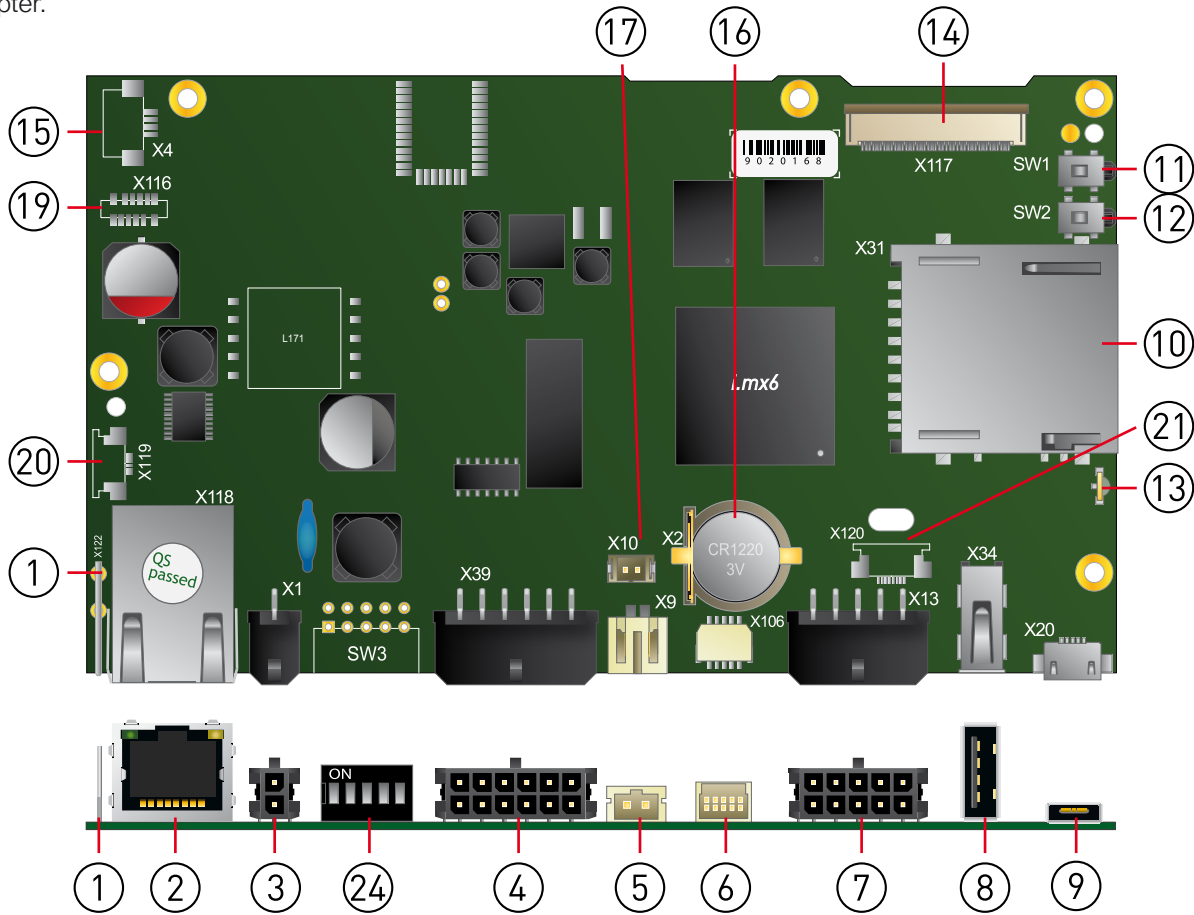

(Exemplary Illustration front side. The illustration shows the fully equipped Santino Dualcore light. It shows no heatsink to provide a better overview.)

Pos.	Description
1	GND Shield connector (X122)
2	Ethernet (X118)
3	Power (X1)
4	CAN/RS-485 Interface (X39) optional with galvanic isolation
5	Speaker (X9)
6	Keypad/Capacitive Touch (X106)
7	RS-232/MDB (X13)
8	USB Host (X34)
9	USB OTG (X20)
10	SD card reader (X31)
11	Reset Switch (SW1)
12	Bootselect Switch (SW2) <sup>1</sup>
13	Power LED (D30)

Pos.	Description
14	Display Interface (X117)
15	Resistive Touch (X4)
16	Battery (X2/X112)
17	Speaker internal (X10)
19	Capacitive Touch (X116) Optional
20	Capacitive Touch (X119) Optional
21	Capacitive Touch (X120) Optional
24	Dip Switch for RS485/CAN (SW3)

<sup>1</sup> For the function of this switch please refer in the future to the Flash N Go User Manual.

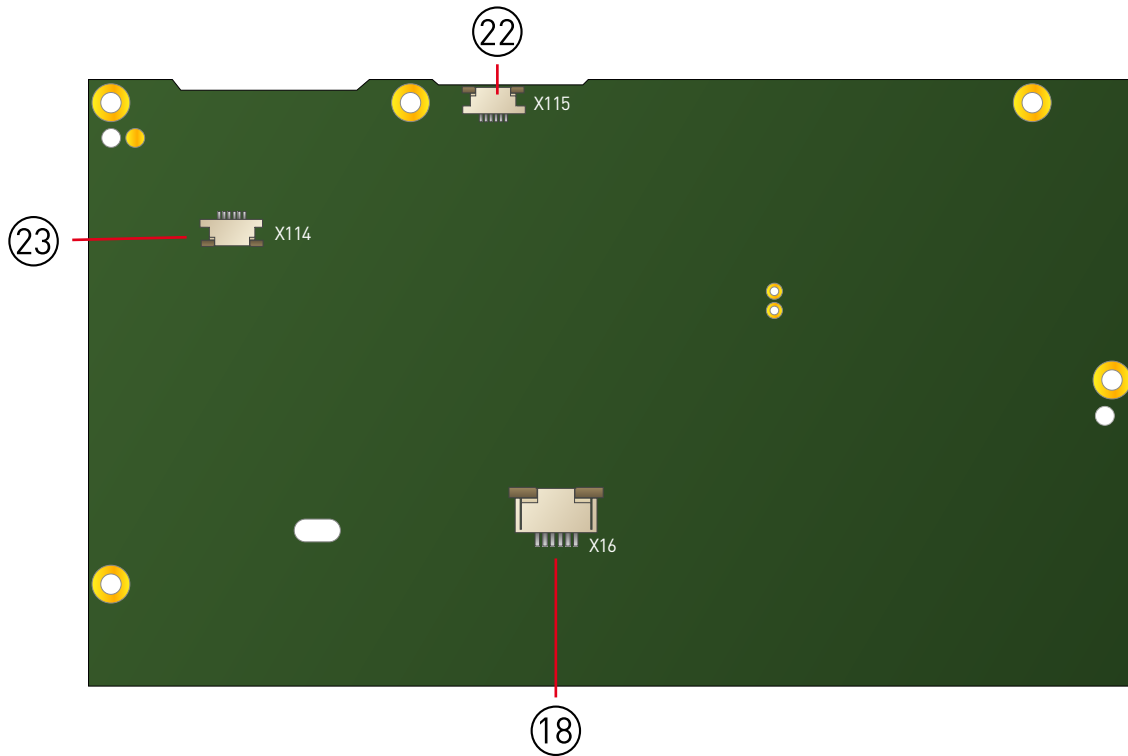

(Exemplary Illustration back side)

Pos.	Description
18	Capacitive Touch (X16)
22	Capacitive Touch (X114) Optional
23	Capacitive Touch (X115) Optional

## 5. Installation and Start Up

The content of this document is limited to explain the device connectors and how to access SANTINO via FTP over your local area network (LAN) within a few seconds. For advanced hardware specifications and software support, please refer to chapter „**3.2 Related Documents and Online Support**“

### 5.1 Connection Scheme

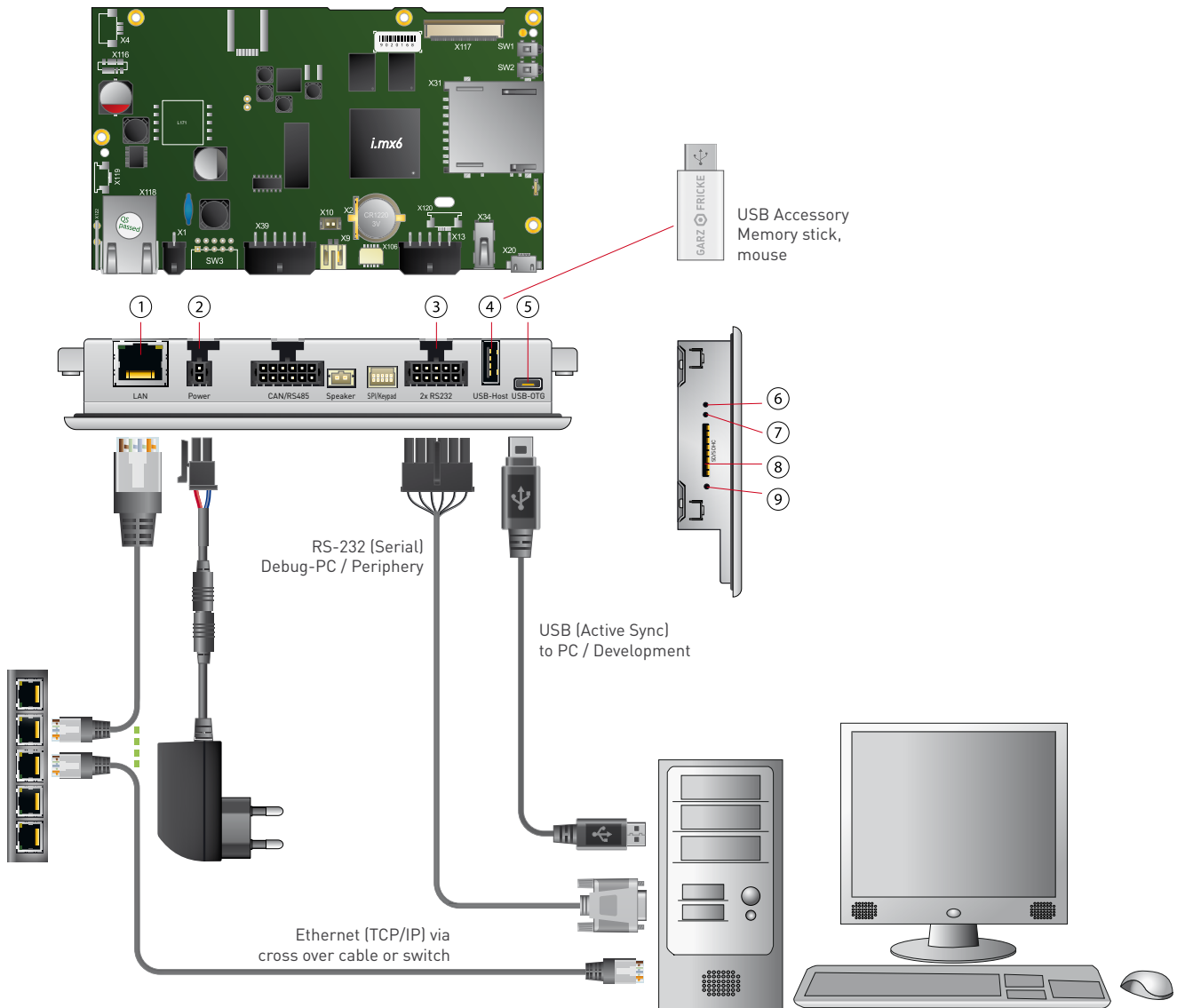

Pos.	Description
1	Ethernet
2	DC in
3	RS-232
4	USB-Device
5	USB Host (OTG)

Pos.	Description
6	Reset sw
7	Bootselect sw
8	SD card slot
9	Power LED



<http://support.garz-fricke.com/projects/Santino/>

## 6. Internal and External Interfaces

### 6.1 GND Shield Connector (X122)



Pin	Name	Description	Information
1	GND	Ground shield	

6.3 mm spade terminal

### 6.2 Ethernet (X118)

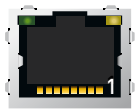

Pin	Name	Description	Information
1	Tx+		Rx/Tx might be swapped (Auto-MDIX) +/- might be swapped (Autom. polarity correction)
2	TX-		
3	RX+		
4	SPARE 1		
5			
6	RX-		
7	SPARE 2		
8			

Header: RJ45

Green LED (link) is default off and turns on when link is detected.

Yellow LED (act) flashes during sending/receiving packets.

### 6.3 Power (X1)



Pin	Name	Description	Level
1	GND	DC Ground	0 V
2	Vcc_In	DC Input voltage	Nom. 9 to 32 V DC

Header: Molex 43045-0200 Micro-Fit 2p  
 Plug: Molex 43025-0200 Micro-Fit 2p,  
 crimp contact Molex 43030-0007  
 Shielding with 6,3 mm male spade terminal connector.



Caution:  
 Power supplies connected to this device must be compliant to the requirements of  
 “limited power sources” (LPS) to prevent the end-user from danger in case of a fault.

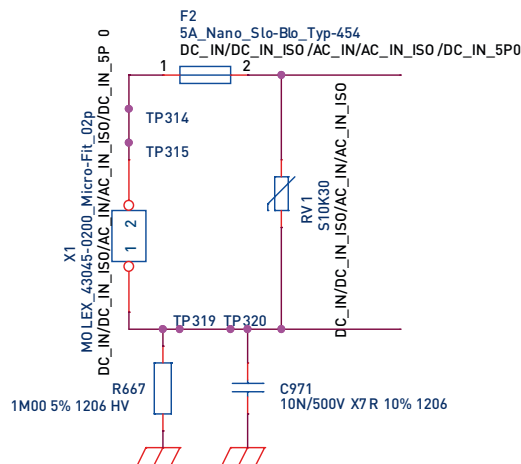

### 6.4 DIP Switch (SW3)



Switch	Function	Description
1/2	RS485 Half Duplex	Switch on for Half Duplex
3	RS485 Termination	Switch on for termination
4/5	CAN Termination	Switch on for termination

## 6.5 CAN/RS-485 Interface (X39)

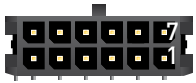

CAN1 Termination

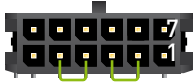

RS485 Termination

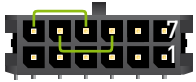

RS485 Half-Duplex

Pin	Name	Description	Level	
1	GND_CAN_RS485	Ground Shield		
2	CAN1_TERM	To enable CAN1-Termination, bridge with CAN1_H		
3	CAN1_H	CAN bus 1 high	-24	+24 V
4	CAN1_L	CAN bus 1 low	-24	+24 V
5	CAN1_TERM	To enable CAN1-Termination, bridge with CAN1_L		
6	RS485_TERM	To enable RS485-Termination: bridge with RS485_A		
7	GND_CAN_RS485	Ground for CAN and RS485 group		
8	n.a.			
9	RS485_Y	TX+	-7	+12 V
10	RS485_Z	TX-	-7	+12 V
11	RS485_A	RX+, to enable Half-Duplex: bridge with RS485_Y		
12	RS485_B	RX-, to enable Half-Duplex: bridge with RS485_Z		

Header: Molex 43045-1200 Micro-Fit 12p

Plug: Molex 43025-1200 Micro-Fit 12p, crimp contact Molex 43030-0007

Shielding with 6,3 mm male spade terminal connector

### CAN1 / CAN2 \*

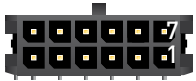

CAN1 Termination

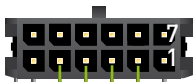

CAN2 Termination

Pin	Name	Description	Level	
1-5		Identical to standard		
6	n.a.			
7	GND_CAN_RS485	Ground for CAN group		
8	CAN2_TERM	To enable CAN2-Termination, bridge with CAN2_H		
9	CAN2_H	CAN bus 2 high	-24	+24 V
10	CAN2_L	CAN bus 2 low	-24	+24 V
11	CAN2_TERM	To enable CAN2-Termination, bridge with CAN2_L		
12	n.a.			

\* alternative assembly upon request



## 6.6 Speaker (X9)



Pin	Name	Description	Level
1	Speaker +	Parallel to X10	1.5W RMS 8 Ohm
2	Speaker -		

Header: JST S2B-PH-SM3-TB

Plug: ST PHR-2 with crimp contacts SPH-002GW-P0.5L-ND

## 6.7 Keypad/SPI (X106)

### Keypad/SPI/I<sup>2</sup>C, multiplexed



Pin	Name	Description Default Mode	Level
1	Power Supply		100 mA
2	GND	Ground	
3	PCK0_GPIO6_7	Keypad row 0	3.3 V
4	PCK1_GPIO6_8	Keypad column 0	
5	PCK2_GPIO6_9	Keypad row 1	
6	PCK3_GPIO6_10	Keypad column 1	
7	PCK4_GPIO6_11	Keypad row 2	
8	PCK5_GPIO6_15	Keypad column 2	
9	I2C1_SDA	I <sup>2</sup> C data	
10	I2C1_SCL	I <sup>2</sup> C clock	

Header: JST DF20F-10DP, side entry, RM = 1.00

Plug: JST DF20-10DS-1C, crimp contact: DF20 F2830 SCF A

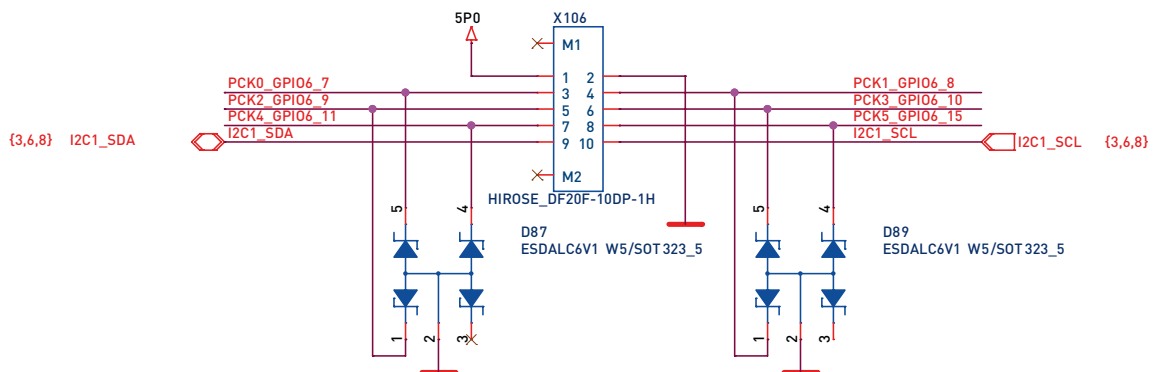

#### Digital output Specification (3.3 V):

V<sub>OH</sub>: min OVDD-0.15; V<sub>OL</sub> max: 0.15V

Drive Strength (Software defined)	I <sub>OL</sub> (mA)	I <sub>OH</sub> (mA)
Low	5.1	-5.1
Medium	10.2	-10.2
High	15.3	-15.3

## 6.8 RS-232/RS-232 (X13)

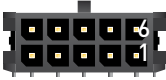

Pin	Name	Description	Level
1	GND	Ground Shield	
2	RS232_TXD1	Port#1: Transmit data (Output)	
3	RS232_RXD1	Port#1: Receive data (Input)	
4	RS232_RTS1	Port#1: Request-to-send (Output)	
5	RS232_CTS1	Port#1: Clear-to-send (Input)	
6	GND	Ground Signal	
7	RS232_TXD2	Port#2: Transmit data (Output)	
8	RS232_RXD2	Port#2: Receive data (Input)	
9	RS232_RTS2	Port#2: Request-to-send (Output)	
10	RS232_CTS2	Port#2: Clear-to-send (Input)	

Header: Molex 43045-1000 Micro-Fit 10p  
 Plug: Molex 43025-1000 Micro-Fit 10p,  
 crimp contact Molex 43030-0007  
 Shielding with 6,3 mm male spade terminal connector

## RS-232/MDB \*



Pin	Name	Description	Level
1-6		Identical to standard	
7	MDB_TXD	MDB: Transmit data (Output)	
8	MDB_RXD2	MDB: Receive data (Input)	
9	MDB_WakeUp	MDB: WakeUp Signal (Output)	
10		MDB: WakeUp PullUp VCC	0.5 V

\* alternative assembly upon request

## 6.9 USB Host (X34)



Pin	Name	Description	Level
1	USB_H1_VBUS	Power supply	+5 V DC max 500mA
2	USB_H1_DN	Data minus (D-)	
3	USB_H1_DP	Data plus (D+)	
4	GND	Ground	

Header: USB Type A

## 6.10 USB OTG (X20)



Pin	Name	Description	Level
1	USB_OTG_VBUS	Power supply	+5 V DC max 100 mA
2	USB_OTG_DN	Data minus (D-)	
3	USB_OTG_DP	Data plus (D+)	
4	USB_OTG_ID	Device ID	
5	GND	Ground	

Header: Micro-USB Type AB

## 6.11 SD Card Reader (X31)

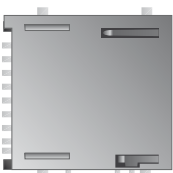

Pin	Name	Description	Level
1	DAT3		
2	CMD	Pullup	3.3 V
3	GND		
4	VDD		80 mA
5	CLK		
6	GND		
7	DAT0		
8	DAT1		
9	DAT2		

## **6.12 Reset Switch (SW1)**

Push for a power on reset.

## **6.13 Bootselect Switch (SW2)**

Push during a power on sequence to boot into the Flash-N-Go.

## **6.14 Power LED (D30)**

Should be green when the device is powered up.

## 6.15 Display Interface (X117)



Pin	Name	Description	Level
1	GND		
2	GND		
3	Dimming	PWM Output	3.3 V
4	LED Power	5.0 V	
5	LED Power		
6	LED Power		
7	VDD LCD	3.3 V	3.3 V +-3%
8	VDD LCD		
9	DE		
10	VSS	GND	
11	VSS		
12	VSS		
13	B5	Data blue MSB	3.3 V
14	B4	Data blue 4	
15	B3	Data blue 3	
16	VSS	GND	
17	B2	Data blue 2	3.3 V
18	B1	Data blue 1	
19	B0	Data blue LSB	
20	VSS	GND	
21	G5	Data green MSB	3.3 V
22	G4	Data green 4	
23	G3	Data green 3	
24	VSS	GND	
25	G2	Data green 2	3.3 V
26	G1	Data green 1	
27	G0	Data green LSB	
28	VSS	GND	
29	R5	Data red MSB	3.3 V
30	R4	Data red 4	
31	R3	Data red 3	
32	VSS	GND	
33	R2	Data red 2	3.3 V
34	R1	Data red 1	
35	R0	Data red LSB	
36	VSS	GND	
37	VSS	GND	
38	DCLK	Data clock	3.3 V
39	VSS	GND	
40	VSS	GND	

Header: HIROSE DF19G-20P-1H  
 Plug: HIROSE DF19G-20S-1C

## 6.16 Resistive Touch (X4)

Compatible with 4-wire resistive touch screens.

For further information see ST Microelectronic's datasheet STMPE610



Pin	Name	Description	Level
1	XP		
2	YN		
3	XN		
4	YP		

Header: Molex 52207-0433 or 52207-0485

Cable: FFC/FPC

## 6.17 Battery-Holder (X2)



Pin	Name	Description	Level
1	VCC	Supply	3 V
2	GND	Ground	

Header: Keystone 1056  
Battery: CR1220

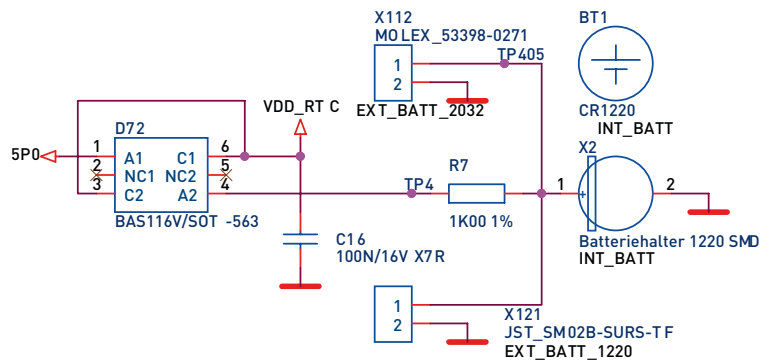

## Battery Connector (X112) \*

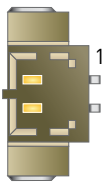

Pin	Name	Description	Level
1	VCC	Supply	3 V
2	GND	Ground	

Header: Molex 53398\_0271  
Plug: Molex 51021\_0200

\* alternative assembly upon request

Connector X112 / Optional: external battery instead of battery holder



## 6.18 Speaker Internal (X10)



Pin	Name	Description	Level
1	Speaker +	Parallel to X9	1.5W RMS 8 Ohm
2	Speaker -		

Header: JST B2B-ZR-SM4-TF

Plug: ZHR-2 with crimp contacts SZH-003T-P0.5

## 6.19 Capacitive Touch (X16)



Pin	Name	Description	Level
1	5 V	Supply	5V max 300mA
2	I <sup>2</sup> C SDA		1kOhm Pullup intern
3	I <sup>2</sup> C SCL		1kOhm Pullup intern
4	GND	Ground	
5	Reset#	Digital Output	1kOhm Pulldown intern
6	Int#	Digital Input	1kOhm Pullup intern

Header: Molex 52207\_0660\_FFC\_6x1mm\_TOP

Cable: FFC/FPC

### Capacitive Touch (X116) \*



Pin	Name	Description	Level
1	VN	Supply	5V max 300mA
2	GND	Ground	
3	Reset#	Digital Output	1kOhm Pulldown intern
4	I <sup>2</sup> C SCL		1kOhm Pullup intern
5	I <sup>2</sup> C SDA		1kOhm Pullup intern
6	Int#	Digital Input	1kOhm Pullup intern
7	NC		not connected
8	NC		not conected

Header: Molex 52559-0834 Pitch=0.5mm  
 Cable: FFC/FPC

### Capacitive Touch (X119) \*



Pin	Name	Description	Level
1	GND	Ground	
2	I <sup>2</sup> C SCL		1kOhm Pullup intern
3	I <sup>2</sup> C SDA		1kOhm Pullup intern
4	VIN	Supply	5V max. 300 mA
5	Int#	Digital Input	1kOhm Pullup intern
6	Reset#	Digital Output	1kOhm Pulldown intern

Header: Molex 52745-0633 Pitch=0.5mm Top Contact  
 Cable: FFC/FPC

### Capacitive Touch (X120) \*



Pin	Name	Description	Level
1	VIN	Supply	5V max 300mA
2	GND	Ground	
3	Reset#	Digital Output	1kOhm Pulldown intern
4	I <sup>2</sup> C SCL		1kOhm Pullup intern
5	I <sup>2</sup> C SDA		1kOhm Pullup intern
6	Int#	Digital Input	1kOhm Pullup intern
7	NC		not connected
8	NC		not conected

Header: Molex 52745-0833 Pitch: 0.5mm Top Contact  
 Cable: FFC/FPC

\* alternative assembly upon request

## Capacitive Touch (X115) \*



Pin	Name	Description	Level
1	VDD	Supply	
2	I <sup>2</sup> C SCL		1kOhm Pullup intern
3	I <sup>2</sup> C SDA		1kOhm Pullup intern
4	Int#	Digital Input	1kOhm Pullup intern
5	Reset#	Digital Output	1kOhm Pulldown intern
6	GND	Ground	

Header: Molex 54548-0670 Pitch=0.5mm Bottom Contact  
 Cable: FFC/FPC

## Capacitive Touch (X114) \*



Pin	Name	Description	Level
1	GND	Ground	
2	I <sup>2</sup> C SDA		1kOhm Pullup intern
3	I <sup>2</sup> C SCL		1kOhm Pullup intern
4	VIN	Supply	5V max. 300 mA
5	Int#	Digital Input	1kOhm Pullup intern
6	Reset#	Digital Output	1kOhm Pulldown intern

Header: Molex 54548-0670 Pitch=0.5mm Bottom Contact  
 Cable: FFC/FPC

\* alternative assembly upon request

## 7. Battery

### 7.1 Battery Specifications

The internal baseboard is equipped with a Primary Lithium battery (type CR1220), which has a typical lifetime of 8 years.

Type	SECO Northern Europe Article Number
Battery type CR 1220	010-0059R

Manufacturer	Model
Camelion	CR1220
Renata	CR1220 MFR
Alpha 3 Manufacturing Ltd.	YOBCR1220
Keystone	1220
Maxell	CR1220

One of these brands must be installed.



Danger of explosion when replaced with wrong type of battery.  
 Replace the battery only with a Lithium battery that has the same or equivalent type recommended by SECO Northern Europe GmbH.



Do not dispose of used CMOS batteries in domestic waste.  
 Dispose of the battery according to the local regulations dealing with the disposal of these special materials (e. g. to the collecting points for disposal of batteries).

## 7.2 Replacement of the Internal Battery

The internal battery is placed as per figure below.  
The device shall be handled by authorized and skilled personnel only.



Danger of electric hazard! First before removing battery, please make sure that the unit is completely disconnected from any power supply, direct or indirect.  
Furthermore take care about the socket and connectors. Especially the micro USB connector might be damaged easily.

### SANTINO core

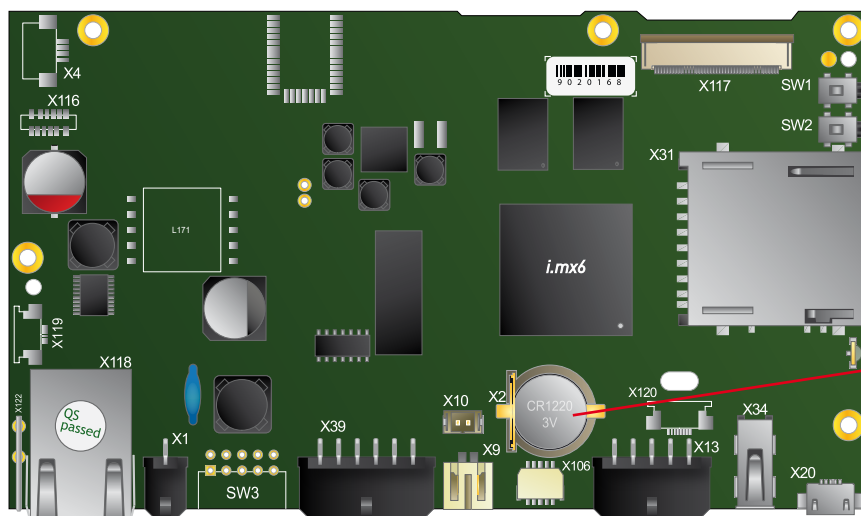

Position of the battery

## Annex A: Hardware Revision Information

This document is applicable for all products listed below. Please note that customized variants might possibly not support all features listed herein. Additional features are documented in specific attachments.

Platform	Article Number	Marking on PCB
<b>SANTINO core x1</b>	900-3398R	0597 SANTINO V1.0
<b>SANTINO core x2I</b>	900-3249R	0597 SANTINO V1.0

Hardware Revision	Marking on PCB
<b>V1.0</b>	0597 SANTINO V1.0

## Annex B: Assembly Options

### B-1 Wi-Fi / Bluetooth

Some appliances require a wireless network connection. To be more flexible with regard to future Wi-Fi standards and regulations, we decided not to assemble this functionality directly onto the single-board-computer. We recommend an external USB or miniPCIe solution. Drivers for both versions will be included in the related operating systems. Please contact the support for information about supported modules.





## Annex C: Guidelines and Standards

### C-1 RoHS Declaration

Devices comply with the requirements of Directive 2011/65/EU of the European Parliament and of the Council of 8th June 2011 on the restriction of the use of certain hazardous substances in electrical and electronic equipment.

### C-2 Supplier Declaration – Directive EG 1907/2006 REACH

SECO Northern Europe is manufacturer of electronic products, thus - in the sense of REACH - we are so called „downstream users“. The products we supply to you are solely non-chemical products (goods). Moreover and under normal and reasonably foreseeable circumstances of application, the goods supplied to you shall not release any substance. For that, SECO Northern Europe is neither obligatory for registration nor for the creation of material safety data sheet (MSDS).

From state of knowledge today our products contain no substances of very high concern from the current SVHC candidate list of the European Chemicals Agency in percentage >0,1.

We will immediately inform you in correspondence to REACH-Article 33 if any substance of content >0,1 percentage in our goods will be classified alarming by the ECHA. Based on the current status, however, we do not expect such an incidence.

### C-3 UL Certification

Customers of SECO Northern Europe are attending on different markets. These markets are subjected to different UL certifications. Therefore SECO Northern Europe have no UL certification for their products.

To obtain UL certifications the product is designed to respect the following constraints:

- ▶ All electronic printed circuit boards are conform to UL standard
- ▶ Battery schematics meets the requirements of UL standard (please refer to chapter „**6.17 Battery-Holder (X2)**“)
- ▶ All wirings are designed with UL components
- ▶ The selected components on the markets are UL (List of UL relevant components is available at SECO Northern Europe (on request))

**SECO Northern Europe do not guarantee to obtain UL certifications.**

## **C-4 SECO Northern Europe Conformity Statement**

SECO Northern Europe GmbH develops and distributes reliable, Arm®-based embedded solutions. We offer various solutions from computer-on-modules (COM) to single-board computers (SBC) and fully-assembled human machine interface (HMI) with pre-installed operating system, display and housing.

These solutions are offered exclusively as OEM products. They do not include any application software that is intended for the end user. Therefore, we do not make any EU declarations of conformity in the name of SECO Northern Europe GmbH and do not provide the products with the CE mark.

Our customers provide the products with application software and build them into an end-user device as part of an industrial production process. They identify themselves as a manufacturer by affixing a license plate with their company or brand name.

We are happy to assist our customers when they compile the necessary technical documentation for the EU Declaration of Conformity of the complete device. We provide e.g. Supplier declarations or RoHS certifications, issue EMC testing results and carry out safety / radio / SAR tests, etc.

## Annex D: Common Documentation

### D-1 Warranty Hints



SECO Northern Europe embedded systems are subject to manufacturer's warranty as long as the products are handled with adequate care and caution and in accordance to this manual.

The period of guarantee starts from the date of shipment

The products are warranted against defects in material, quality and functionality within the warranty period.

During this period, the repair of the products is free of charge.

SECO Northern Europe will decide for repair or replacement at their own discretion.

If the product has been returned with or without prior notice and no failure or malfunction can be detected or the failure or malfunction is caused by inappropriate handling or the device has been returned after expiry of warranty period, SECO Northern Europe reserve the right to charge the user for repair or replacement.



The warranty does not cover defects caused by improper or inadequate installation, maintenance or handling by the user, unauthorized modification or misuse, operation outside the specification or non-compliance of this manual. In case of doubt, please contact the technical sales team prior to intended activity.

The warranty does also not cover any defects or damages of other equipment connected to the SECO Northern Europe product, faulty or not.

For warranty or repair service, please contact the technical sales team.

**[support.north@seco.com](mailto:support.north@seco.com)**  
**[rma.north@seco.com](mailto:rma.north@seco.com)**

## **D-2 Field of Application**

The products covered by this document are designed and manufactured for the following applications (I). If you intend to use these products in applications as quoted in (II) we highly recommend a personal contact with our consultants and/or technical sales team.

### **(I) Recommended application areas for SECO Northern Europe embedded systems**

Even for these applications, we recommend to get in contact with our technical sales team. We offer a wide range of support, even at an early stage of evaluation and/or design-in phase.

- ▶ Vending machines and gastronomy devices
- ▶ Industrial controllers and HMI systems
- ▶ Home automation and facility management
- ▶ Audiovisual equipment
- ▶ Instrumentation and measuring equipment

### **(II) Restricted application areas, prior consultation is mandatory to identify and meet the individual regulatory requirements**

- ▶ Gas leak detectors
- ▶ Rescue and security equipment
- ▶ Safety devices
- ▶ Control and safety devices for airplanes, trains, automobiles and other transportation equipment
- ▶ Traffic control systems
- ▶ Control equipment for nuclear power industry
- ▶ Medical equipment related to life support etc.
- ▶ Gasoline stations and oil raffineries

## **Annex E: Technical Support**

Before contacting the SECO Northern Europe support team, please try to help yourself by the means of this manual or any other documentation provided by SECO Northern Europe or the related websites.

If this does not help at all, please feel free to contact us.

Our technicians and engineers will be glad to support you. Please note that beyond the support hours included the Starter Kit, various support packages are available. To keep the pure product cost at a reasonable level, we have to charge support and consulting services per effort.

### **Shipping Address:**

SECO Northern Europe GmbH  
Schlachthofstrasse 20  
21079 Hamburg  
Germany

### **Support Contact:**

Phone: +49 (0) 40 / 791 899-200  
Fax: +49 (0) 40 / 791 899-39  
E-Mail: [support.north@seco.com](mailto:support.north@seco.com)  
URL: [north.seco.com](http://north.seco.com)

## **Annex F: General Information**

### **Trademarks and service marks**

Names and logos in this document may be trademarks of their respective companies.

In some cases descriptions for copyrighted products are not explicitly indicated as such. The absence of the trademark (™) and copyright (©) symbols does not imply that a product is not protected. Additionally, registered patents and trademarks are similarly not expressly indicated.

### **Drawings**

All drawings, which are shown in this manual are schematic drawings.

For exact technical drawings please refer to our sales team or product manager

All other product or service names are the property of their respective owners.

All rights reserved. Products subject to technical changes, improvements and misprints.

© 2022 SECO Northern Europe GmbH