

NALLINO core

Arm® Cortex®-A7 Single Board Computer

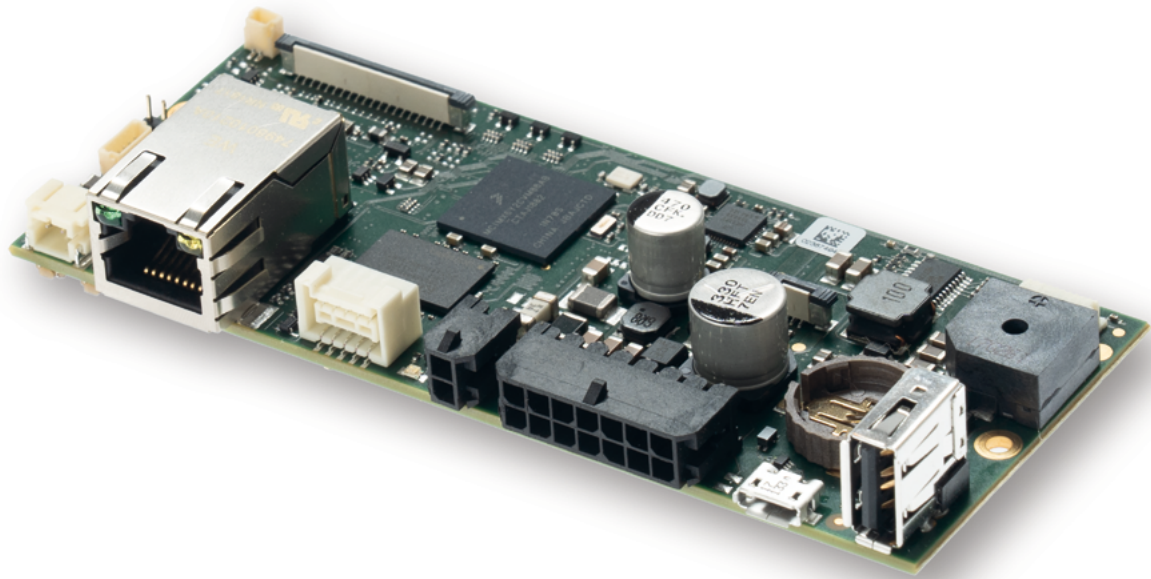

Small sized form factor with high performance for displays up to 5.0".

Product Manual

Document Revision History

The information in this document is subject to change without prior notice in order to improve reliability, design and function and does not represent a commitment on the part of the manufacturer.

Revision	Date	Author	Description
V 1	05.02.2020	CG	Initial Release
V 2	16.09.2020	CG	Changes Page 8
V 3	11.11.2020	CG	Changes Page 8
V 4	16.11.2021	SK	Changes Page 14
V 5	17.12.2021	bmy	SECO CI Update 2022

Online support on edge.seco.com

Table of Contents

1.	Introduction	4
2.	Safety Hints	5
3.	Product Introduction	6
3.1	Type Plate and Device Information	6
3.2	Related Documents and Online Support.....	7
4.	Technical Data	8
4.1	Block Diagram SBC	9
4.2	Technical Drawing	10
4.3	Connectors.....	11
5.	Installation and Start Up	12
5.1	Connection Scheme	12
6.	Internal and External Interfaces	13
6.1	Speaker (X801)	13
6.2	Ethernet (X900)	13
6.3	Keypad / I ² C (X701)	14
6.4	SD Card Reader (X705)	15
6.5	Power (X200/X201).....	16
6.6	CAN/RS-485 Interface (X1000).....	17
6.7	USB OTG (X1301).....	18
6.8	USB Host (X1300).....	18
6.9	Expansion Connector WiFi/BT (X700).....	19
6.10	Battery Connector (X1203).....	19
6.11	Capacitive Touch Connector (X1200)	20
6.12	Display Connector (X600).....	21
6.13	Backlight Connector (optional) (X601).....	22
6.14	JTAG - Debug Interface (X500).....	22
6.15	I ² C Connector (X1201)	22
6.16	Reset Switch (SW500).....	22
6.17	BOOT-Select Switch (SW501)	22
6.18	Power LED (X?)	22
7.	Battery	23
7.1	Battery Specifications.....	23
7.2	Replacement of the Internal Battery	24
Annex A:	Hardware Revision Information	25
Annex B:	Assembly Options	26
B-1	Wi-Fi / Bluetooth	26
Annex C:	Guidelines and Standards	27
C-1	RoHS Declaration.....	27
C-2	Supplier Declaration – Directive EG 1907/2006 REACH.....	27
C-3	UL Certification.....	27
C-4	SECO Northern Europe Conformity Statement.....	28
Annex D:	Common Documentation	29
D-1	Warranty Hints	29
D-2	Field of Application.....	30
Annex E:	Technical Support	31
Annex F:	General Information	32

1. Introduction

Thank you very much for purchasing a SECO Northern Europe product. Our products are dedicated to professional use and therefore we suppose extended technical knowledge and practice in working with such products.



The information in this manual is subject to technical changes, particularly as a result of continuous product upgrades. Thus this manual only reflects the technical status of the products at the time of printing. Before design-in the device into your or your customer's product, please verify that this document and the therein described specification is the latest revision and matches to the PCB version. We highly recommend contacting our technical sales team prior to any activity of that kind.

The attached documentation does not entail any guarantee on the part of SECO Northern Europe GmbH with respect to technical processes described in the manual or any product characteristics set out in the manual. We do not accept any liability for any printing errors or other inaccuracies in the manual unless it can be proven that we are aware of such errors or inaccuracies or that we are unaware of these as a result of gross negligence and SECO Northern Europe has failed to eliminate these errors or inaccuracies for this reason. SECO Northern Europe GmbH expressly informs that this manual only contains a general description of technical processes and instructions which may not be applicable in every individual case. In cases of doubt, please contact our technical sales team.

In no event, SECO Northern Europe is liable for any direct, indirect, special, incidental or consequential damages arising out of use or resulting from non-compliance of therein conditions and precautions, even if advised of the possibility of such damages.



Before using a device covered by this document, please carefully read

- ▶ **Annex „D-1 Warranty Hints“**
- ▶ **Annex „D-2 Field of Application“**



Embedded systems are complex and sensitive electronic products. Please act carefully and ensure that only qualified personnel will handle and use the device at the stage of development. In the event of damage to the device caused by failure to observe the hints in this manual and on the device (especially the safety instructions), SECO Northern Europe shall not be required to honour the warranty even during the warranty period and shall be exempted from the statutory accident liability obligation. Attempting to repair or modify the product also voids all warranty claims.

2. Safety Hints

Please read this section carefully and observe the instructions for your own safety and correct use of the device. Observe the warnings and instructions on the device and in the manual. SECO Northern Europe embedded systems have been built and tested by us and left the company in a perfectly safe condition. In order to maintain this condition and ensure safe operation, the user must observe the instructions and warnings contained in this manual.



I. General Handling

- ▶ Don't drop or strike the unit: The PCB, display and/or other parts might be damaged.
- ▶ Keep away from water and other liquids, the unit is not protected against.
- ▶ Operate the unit under electrical and environmental conditions according to the technical specification.
- ▶ The electrical installations in the room must correspond to the requirements of the local (country-specific) regulations.
- ▶ Take care that there are no cables, particularly power cables, in areas where persons can trip over them.
- ▶ Do not place the device in direct sunlight, near heat sources or in a damp place.
- ▶ All plugs on the connection cables must be screwed or locked to the housing.
- ▶ Repairs may only be carried out by qualified specialist personnel authorized by SECO Northern Europe GmbH or their local distributors.
- ▶ Maintenance or repair on the open device may only be carried out by qualified personnel authorized by SECO Northern Europe GmbH which is aware of with the associated dangers.



II. Electricity

- ▶ The embedded systems may only be opened in accordance with the description in this user's manual for
 - replacing of the (rechargeable, where applicable) lithium battery and/or
 - configuration of interfaces, where applicable
- ▶ These procedures have to be carried-out only by qualified specialist personnel.
- ▶ When accessing internal components the device must be switched off and disconnected from the power source.
- ▶ When purchased core or basic versions without protecting back cover, don't touch the PCB directly with your fingers. Especially these products need to be handled very carefully.
- ▶ Don't operate or handle the unit without typical ESD protection measures, such as ground earthing.
- ▶ Operate the unit according to the technical specification only.



III. Damage or Permanent Malfunction

- ▶ It must be assumed that a safe operation is no longer possible, in case
 - the device has visible damage or
 - the display is dark or shows strange pattern for longer period
 - the device doesn't react after a reset
- ▶ In these cases the device must be shut down and secured against further use

3. Product Introduction

This document is applicable for hardware revisions 1.0 or later of the NALLINO series.

Please find the hardware version grid in „**Annex A: Hardware Revision Information**“:

NALLINO is an Embedded System to be used as human machine interface (HMI) in various applications. Please refer to **Annex „D-2 Field of Application“** for further information. The system is equipped with a large number of industrial interfaces. A wide variety of options is available as well.

3.1 Type Plate and Device Information

For service and later identification of the device, the type plate contains important information.

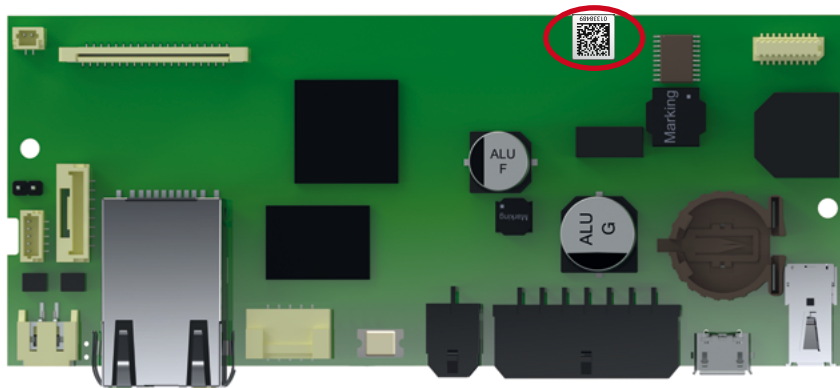

code defines the serial number



3.2 Related Documents and Online Support

This document contains operating system specific information. The following additional documentations are available:

OPERATING SYSTEMS

Linux Yocto Rocko	 https://bit.ly/3xQntJp	Contains information about Linux BSP with development environment Linux Embedded System Yocto (Codename: Rocko, Version 2.4) includes first information about the bootloader Flash-N-Go
-------------------	--	--

UPDATE / BOOT / SYSTEM

U-Boot	
--------	--

4. Technical Data

CPU	Standard	M
CPU Type	i.MX6ULL	
Core Class	Arm® Cortex®-A7	
Core Clock	800 MHz	
Features	NEON for SIMD media acceleration and VFP operations; Display support up to WXGA (1366 x768) at 60 Hz; L1 cache, 32 KB for instruction and 32 KB for data; 128 KB L2 cache	
HW Accelerators	Pixel Processing Pipeline for image resize, rotation, overlay and CSC	
RTC	Accuracy: +/- 30 ppm at 25°C	
Memory		
eMMC Flash	4 GB MLC eMMC	
RAM Standard	512 MB 16 bit DDR3L	
MicroSD Card Slot	4 bit MMC/SDIO/SD/SDHC	
Operating Systems		
Supported OS	Linux Yocto	
Communication Interfaces		
Network	1x 10/100 Mbit/s Ethernet (RJ-45)	
RS-485	1x RS-485 (Half duplex) & 1x CAN (ISO/DIS 11898)	
RS-232	1x RS-232 (RX/TX/CTS/RTS)	
USB 2.0	1x 480 Mbit/s Host (Type A) 1x 480 Mbit/s OTG (Type Micro-AB)	
Synchronous Serial Interfaces	SPI, Matrix Keypad up to 4 x 4	
Audio		
Audio Internal	Buzzer	
Audio Output	1x Speaker connector, 1.5 W RMS (8Ohm)	
Display and Touch		
Display Interface	TTL, 24 bit (RGB)	
Touch Interface	PCAP I ² C (4-wire analog resistive, optional)	
Backlight	Integrated backlight driver (111 mA driving current)	
Device Dimensions		
W x H x D	113.8 x 18.0 x 47.3 mm	
Weight	50g	
Power Supply		
Supply Voltage	Nom. 9 to 32 V DC	Regulated 5 V DC
Consumption	tbd.	tbd.
Typical Environmental Conditions		
Storage Temp.	-20 to +70 °C	
Operating Temp.	0 to 50 °C.	
Humidity	5 to 90 % RH, non-condensing	

4.1 Block Diagram SBC

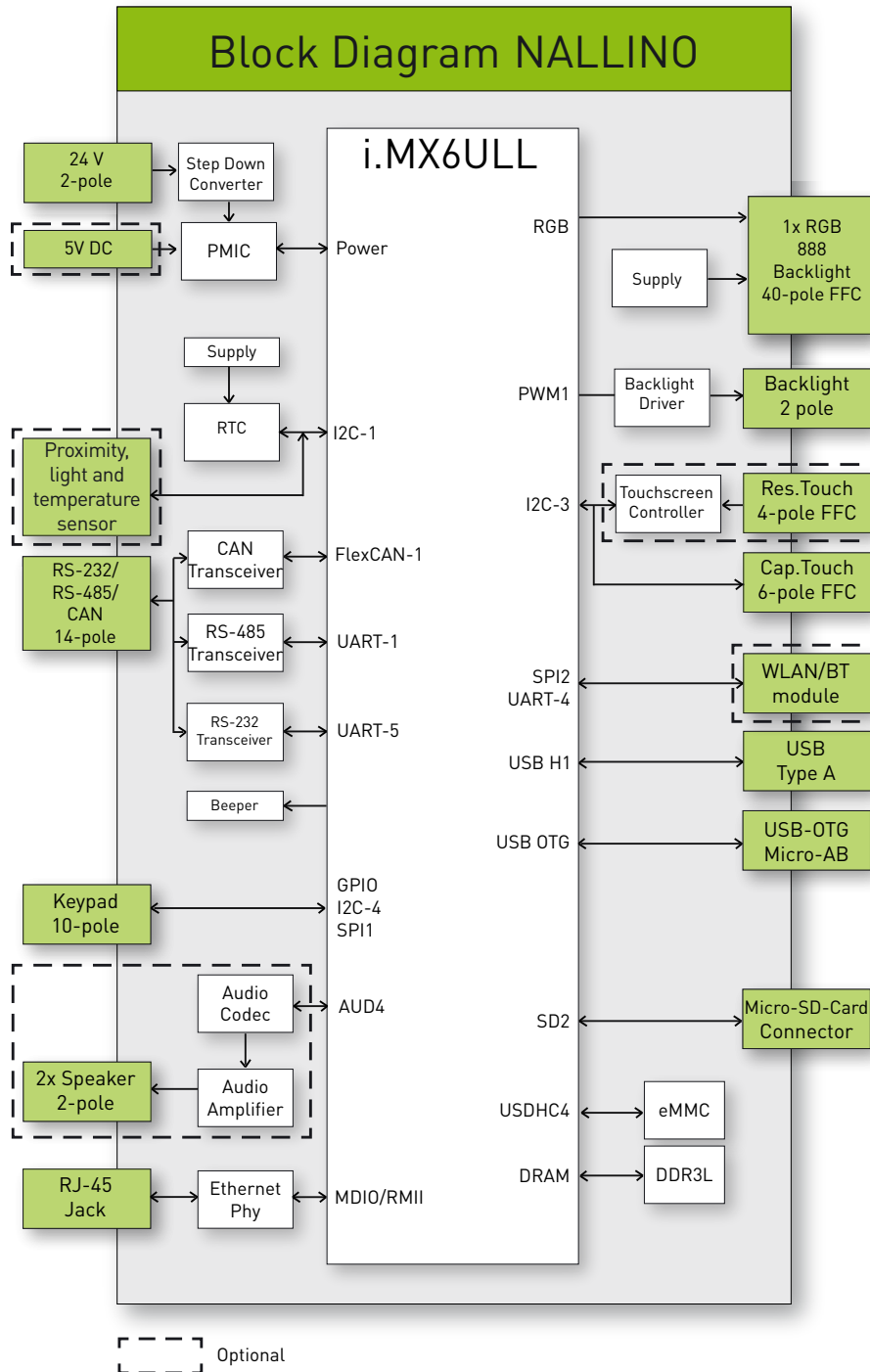

4.2 Technical Drawing

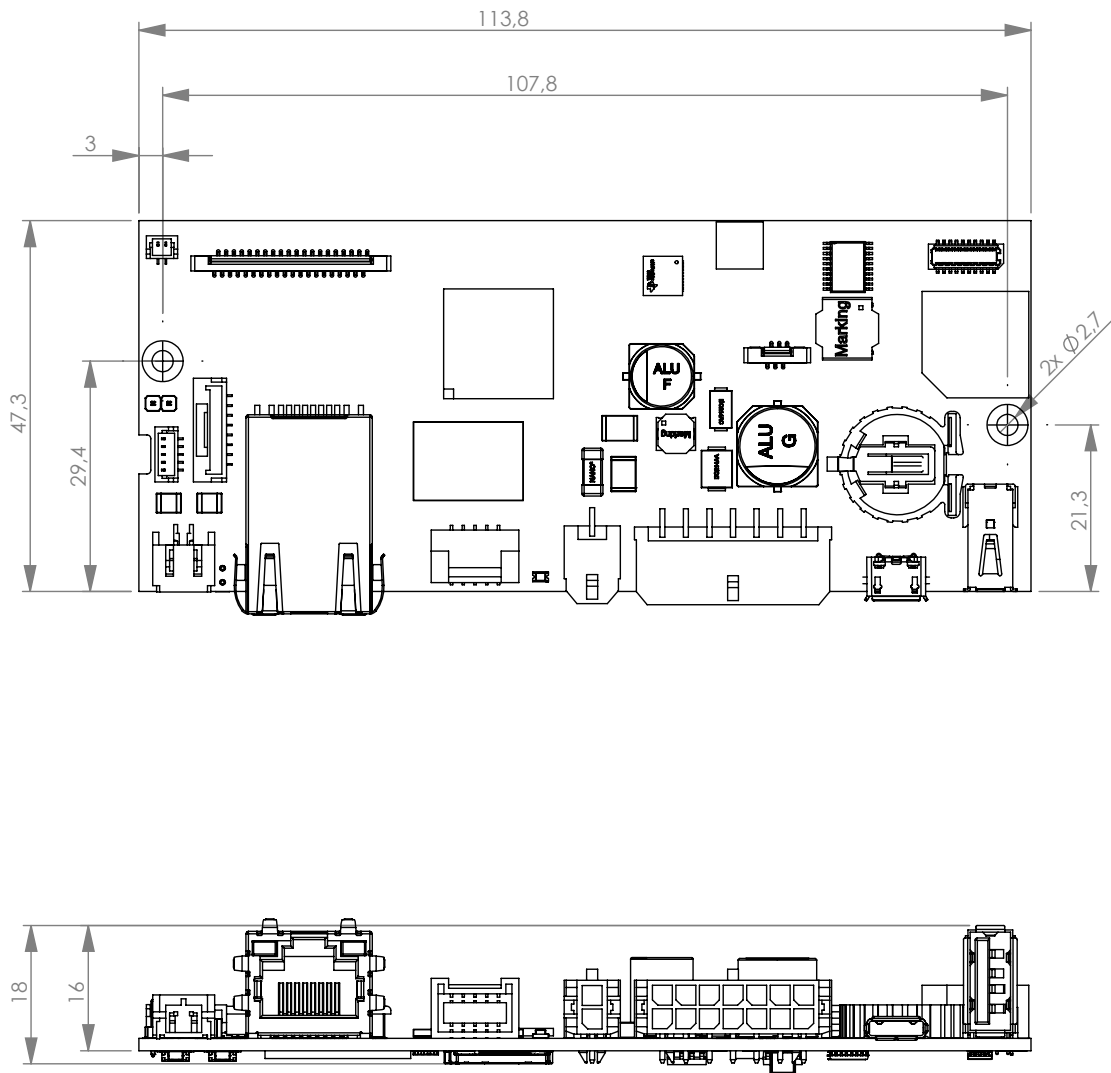

Missing dimensions according to 3D CAD files

4.3 Connectors

As this manual describes a core version, the internal and external interfaces will be mentioned in the following chapter.

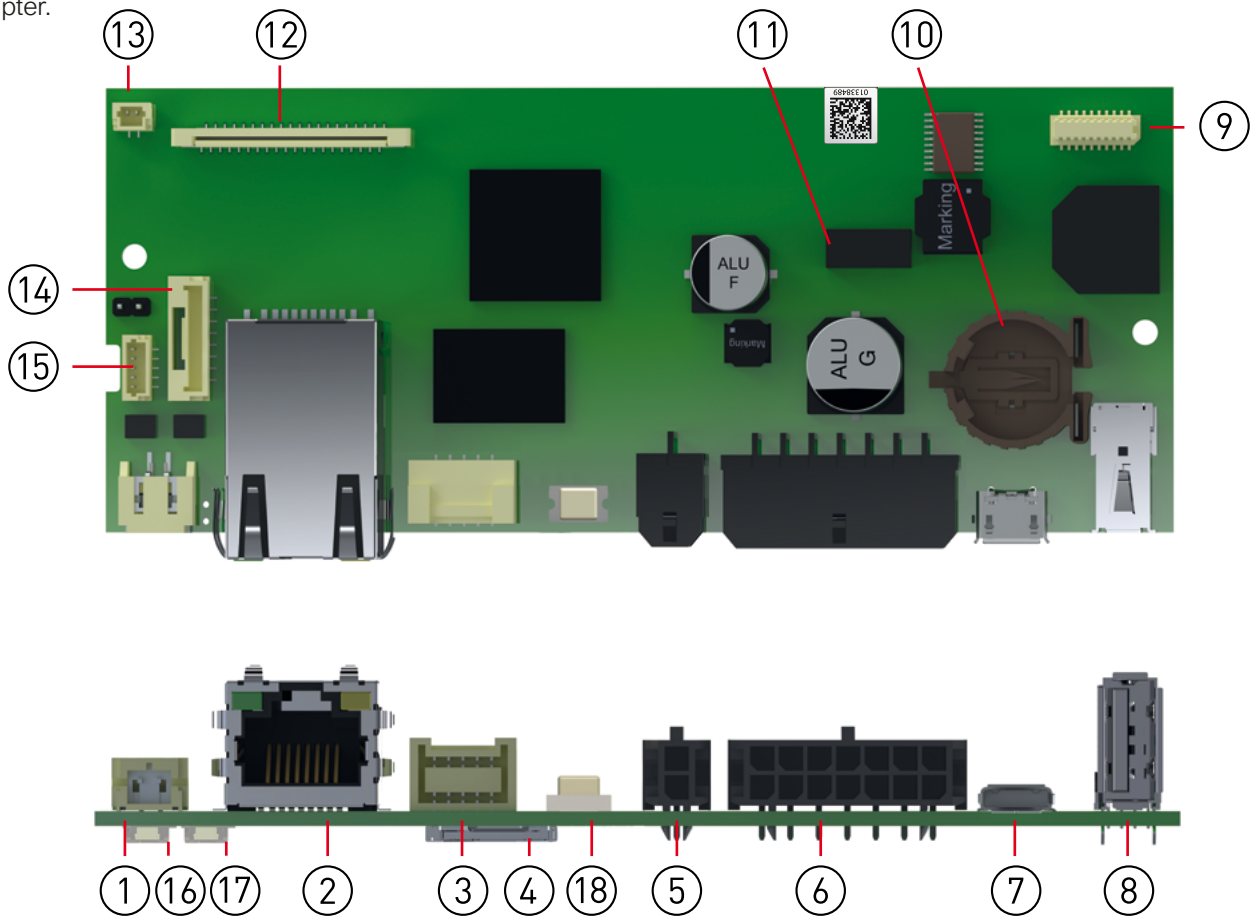

(Exemplary Illustration front side. The illustration shows the fully equipped NALLINO)

Pos.	Description
1	Speaker (X801)
2	Ethernet (X900)
3	Keypad / I ² C Interface (X701)
4	Micro SD Card (X705)
5	Power (X200/X201)
6	CAN/RS-485 / RS-232 Interface (X1000)
7	USB OTG (X1301)
8	USB Host (X1300)

Pos.	Description
9	Expansion Connector WiFi / BT (X700)
10	Battery (X1203)
11	Touch Connector (X1200)
12	Display Connector (X600)
13	Backlight Connector (optional) (X601)
14	JTAG Debug Interface (X500)
15	I ² C-Connector (X1201)
16	Reset Switch (SW500)
17	BOOT-Select Switch (SW501)
18	Power LED (D500)

5. Installation and Start Up

The content of this document is limited to explain the device connectors and how to access NALLINO via FTP over your local area network (LAN) within a few seconds. For advanced hardware specifications and software support, please refer to chapter „**3.2 Related Documents and Online Support**“

5.1 Connection Scheme

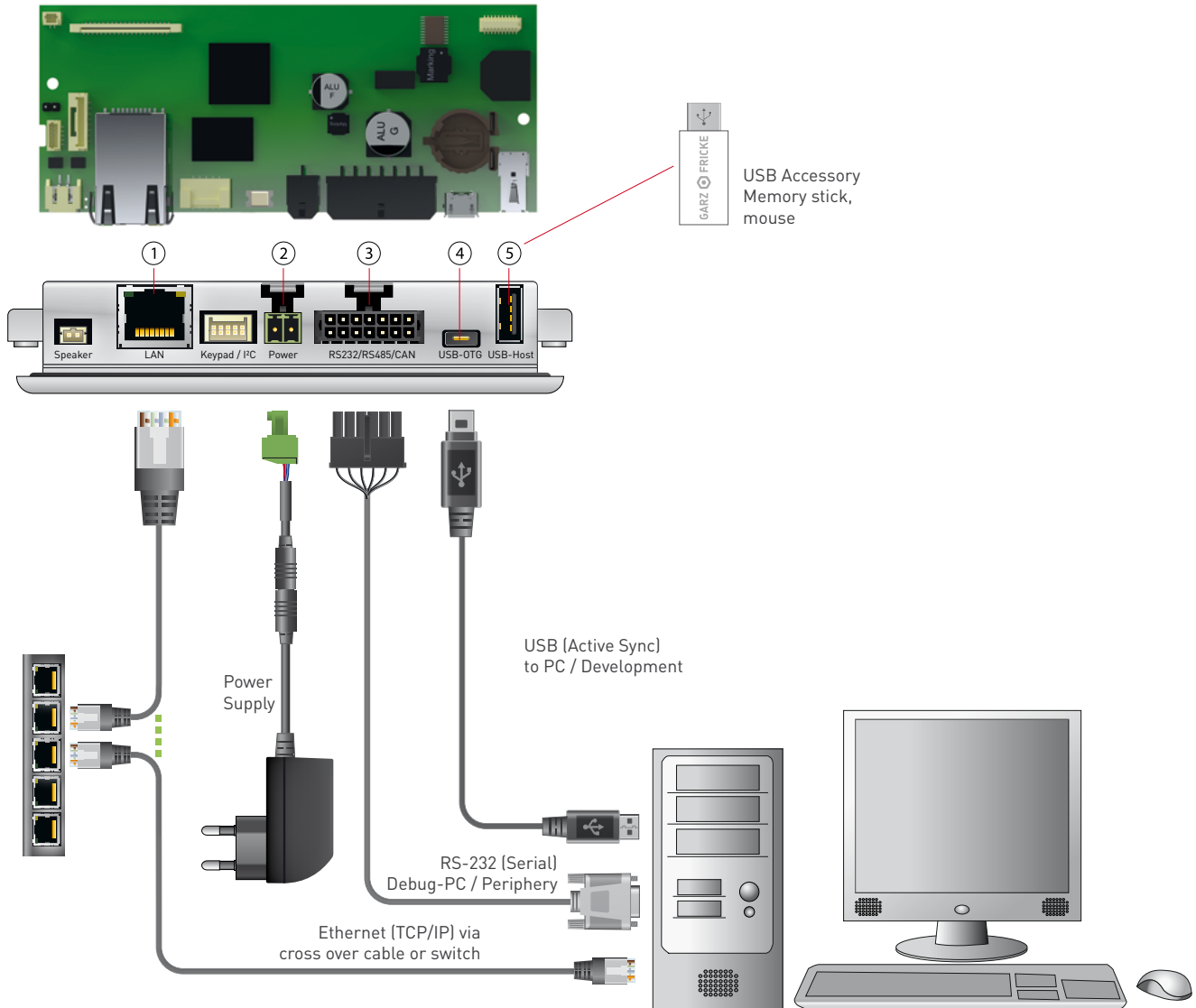

Pos.	Description
1	Ethernet
2	DC in
3	RS-232
4	USB Host (OTG)
5	USB Device

6. Internal and External Interfaces

6.1 Speaker (X801)



Pin	Name	Description	Level
1	Speaker +		1.5W RMS 8 Ohm
2	Speaker -		

Header: JST S2B-PH-SM3-TB

Plug: ST PHR-2 with crimp contacts SPH-002GW-P0.5L-ND

6.2 Ethernet (X900)

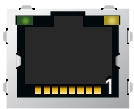

Pin	Name	Description	Information
1	Tx+		Rx/Tx might be swapped (Auto-MDIX) +/- might be swapped (Autom. polarity correction)
2	TX-		
3	RX+		
4	SPARE 1		
5			
6	RX-		
7	SPARE 2		
8			

Header: RJ45

Green LED (link) is default off and turns on when link is detected.

Yellow LED (act) flashes during sending/receiving packets.

6.3 Keypad / I²C (X701)

Keypad/SPI/I²C, multiplexed



Pin	Name	Description Default Mode	Level
1	Power Supply		5.0 V
2	GND	Ground	
3	SPI1_SSO	SPI SSO	3.3 V
4	SPI1_SCLK	SPI CLK	
5	SPI1_MISO	SPI MISO	
6	SPI1_MOSI	SPI1_MOSI	
7	KPCOL-GPIO2	GPIO	
8	KPROW7-GPIO2	GPIO	
9	I2C4_SDA	I ² C data	
10	I2C4_SCL	I ² C clock	

Header: JST SM10B-ZPDSS

Plug: JST ZPDR-10V-S, crimp contact: SZPD-002T-P0.3

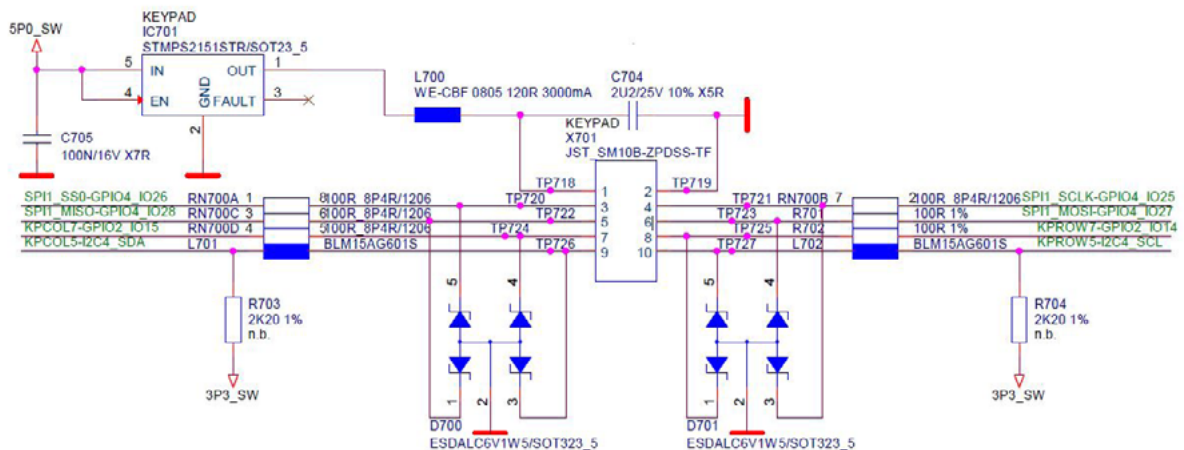

Digital output Specification (3.3 V):

V_{OH}: min OVDD-0.15; V_{OL} max: 0.15V

Drive Strength (Software defined)	I _{OL} (mA)	I _{OH} (mA)
Low	5.1	-5.1
Medium	10.2	-10,2
High	15.3	-15,3

6.4 SD Card Reader (X705)

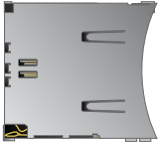

Pin	Name	Description	Level
1	DAT3		
2	CMD	Pullup	3.3 V
3	GND		
4	VDD		3.3 V
5	CLK		
6	GND		
7	DAT0		
8	DAT1		
9	DAT2		

6.5 Power (X200/X201)



Pin	Name	Description	Level
1	GND	DC Ground	0 V
2	Vin+	DC Input voltage	Nom. 9 to 32 V DC

Header: Molex 43045-0200 Micro-Fit 2p
 Plug: Molex 43025-0200 Micro-Fit 2p,
 crimp contact Molex 43030-0007
 Shielding with 6,3 mm male spade terminal connector.
 Power (X1) is not galvanic isolated from System-GND/Housing



Caution:
 Power supplies connected to this device must be compliant to the requirements of
 “limited power sources” (LPS) to prevent the end-user from danger in case of a fault.

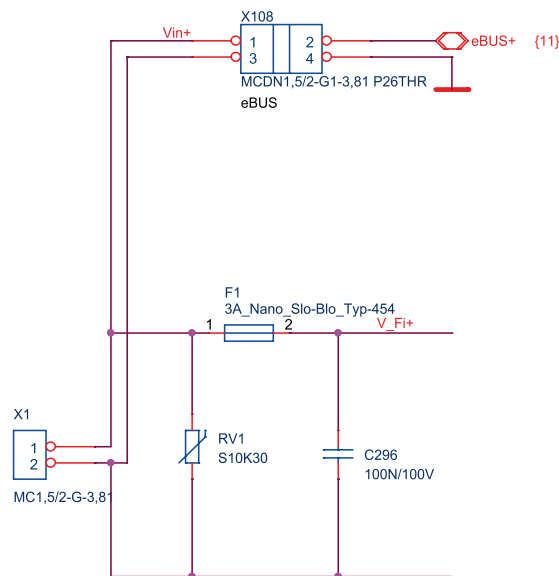

6.6 CAN/RS-485 Interface (X1000)

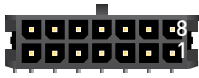

CAN1 Termination

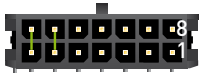

RS485 Termination

Pin	Name	Description	Level
1	GND	Ground	
2	RS-232_TXD1	Port #1: Transmit data (Output)	V. 28
3	RS-232_RXD1	Port #1: Receive data (Input)	V. 28 +24 V
4	RS-232_RTS1	Port #1: Request-to-send (Output)	V. 28 +24 V
5	RS-232_CTS1	Port #1: Clear-to-send (Input)	V. 28
6	RS485_A_T+	RS485 Termination high side, bridge with T+	
7	RS485_B_T-	RS485 Termination low side, bridge with T-	
8	GND	Ground	
9	CAN_H	CAN bus high	
10	CAN_L	CAN bus low	
11	CAN_TERM	To enable CAN-Termination, bridge with CAN_L	
12	GND	Ground	
	RS485_T+	Half Duplex A	
	RS485_T-	Half Duplex B	

Header: Molex 43045-1400 Micro-Fit 14p

Plug: Molex 43025-1400 Micro-Fit 14p, crimp contact Molex 43030-0007

Shielding with 6.3 mm male spade terminal connector CAN/RS-485 is not galvanic isolated from System-GND/Housing

6.7 USB OTG (X1301)



Pin	Name	Description	Level
1	USB_OTG_VBUS	Power supply	+5 V DC max 500mA
2	USB_OTG_DN	Data minus (D-)	
3	USB_OTG_DP	Data plus (D+)	
4	USB_OTG_ID	Device ID	
5	GND	Ground	

Header: Micro-USB Type AB

6.8 USB Host (X1300)



Pin	Name	Description	Level
1	USB_H1_VBUS	Power supply	+5 V DC max 500mA
2	USB_H1_DN	Data minus (D-)	
3	USB_H1_DP	Data plus (D+)	
4	GND	Ground	

Header: USB Type A

6.9 Expansion Connector WiFi/BT (X700)

6.10 Battery Connector (X1203)



Pin	Name	Description	Level
1	VCC	Supply	3 V
2	GND	Ground	

Header: Keystone 1056
 Battery: CR1220

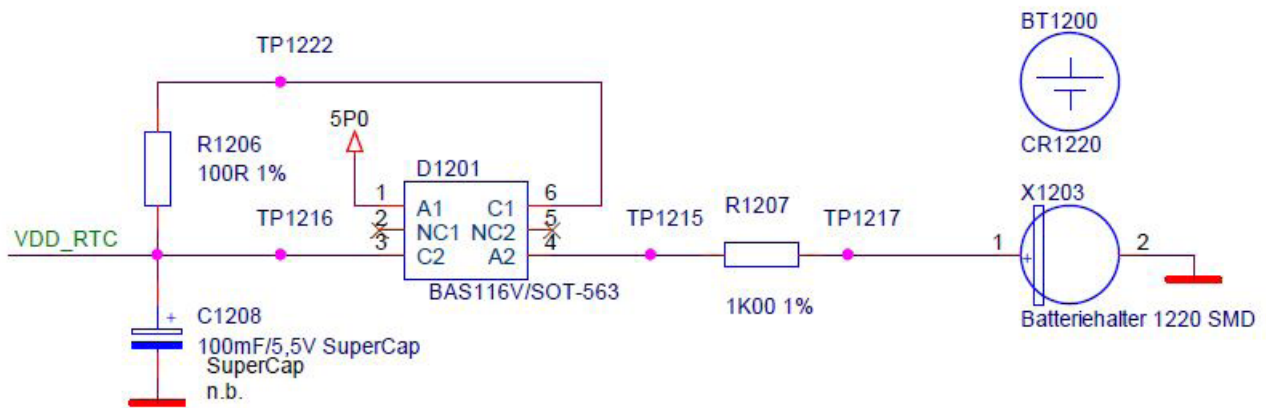

6.11 Capacitive Touch Connector (X1200)

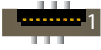

Pin	Name	Description	Level
1	VDD	Supply	3.3 V
2	I2C2_SCL	I ² C Clock	1k Ohm Pullup
3	I2C2_SDA	I ² C data	1k Ohm Pullup
4	CTOUCH_INT#	Interrupt	1k Ohm Pullup
5	CTOUCH_RESET	Reset	1k Ohm Pulldown
6	GND	Ground	

Header: FFC Connector 6x0.5mm

6.12 Display Connector (X600)



Pin	Name	Description	Level	
1	VLEDN	Backlight -	20 mA Backlight driver	
2	VLEDP	Backlight +		
3	GND	Ground		
4	VDD_LCD	Supply display	3.3 V +/- 3%	
5	LCD_R0	Data red LSB	3.3 V	
6	LCD_R1	Data red 1		
7	LCD_R2	Data red 2		
8	LCD_R3	Data red 3		
9	LCD_R4	Data red 4		
10	LCD_R5	Data red 5		
11	LCD_R6	Data red 6		
12	LCD_R7	Data red MSB		
13	LCD_G0	Data green LSB		
14	LCD_G1	Data green 1		
15	LCD_G2	Data green 2		
16	LCD_G3	Data green 3		
17	LCD_G4	Data green 4		
18	LCD_G5	Data green 5		
19	LCD_G6	Data green 6		
20	LCD_G7	Data green MSB		
21	LCD_B0	Data blue LSB		
22	LCD_B1	Data blue 1		
23	LCD_B2	Data blue 2		
24	LCD_B3	Data blue 3		
25	LCD_B4	Data blue 4		
26	LCD_B5	Data blue 5		
27	LCD_B6	Data blue 6		
28	LCD_B7	Data blue MSB		
29	GND	Ground		
30	DISP0_CLK	Data clock		3.3 V
31	LCD_ENA	Enable		3.3 V
32	DISP0_HS	Horizontal sync		3.3 V
33	DISP0_VS	vertical sync	3.3 V	
34	DISP0_DE	Data enable	3.3 V	
35	NC			
36	GND	Ground		
37	NC			
38	NC			
39	NC			
40	NC			

Header: FFC Connector 40x0.5mm

Note: Assembly options for different displays are available on request

6.13 Backlight Connector (optional) (X601)

6.14 JTAG - Debug Interface (X500)



Pin	Name	Description	Level
1	JTAG_TVK		
2	GND		
3	JTAG_TDO		
4	JTAG_MOD		
5	JTAG_TMS		
6	JTAG_TDI		
7	JTAG_TRST_B		
8	J_SRST_B		

6.15 I²C Connector (X1201)

6.16 Reset Switch (SW500)

Push for a power on reset.

6.17 BOOT-Select Switch (SW501)

Push during a power on sequence to boot into the secondary OS.

6.18 Power LED (X?)

7. Battery

7.1 Battery Specifications

The internal baseboard is equipped with a Primary Lithium battery (type CR1220), which has a typical lifetime of 8 years.

Type	SECO Northern Europe Article Number
Battery type CR1220	010-0059R

Manufacturer	Model
Varta	CR1220
Alpha 3 Manufacturing Ltd.	YOBCR1220
Keystone	1220
Maxell	CR1220

One of these brands must be installed.



Danger of explosion when replaced with wrong type of battery.
 Replace the battery only with a Lithium battery that has the same or equivalent type recommended by SECO Northern Europe GmbH.



Do not dispose of used CMOS batteries in domestic waste.
 Dispose of the battery according to the local regulations dealing with the disposal of these special materials (e. g. to the collecting points for disposal of batteries).

7.2 Replacement of the Internal Battery

The internal battery is placed as per figure below.
The device shall be handled by authorized and skilled personnel only.



Danger of electric hazard! First before removing battery, please make sure that the unit is completely disconnected from any power supply, direct or indirect.
Furthermore take care about the socket and connectors. Especially the micro USB connector might be damaged easily.

NALLINO core

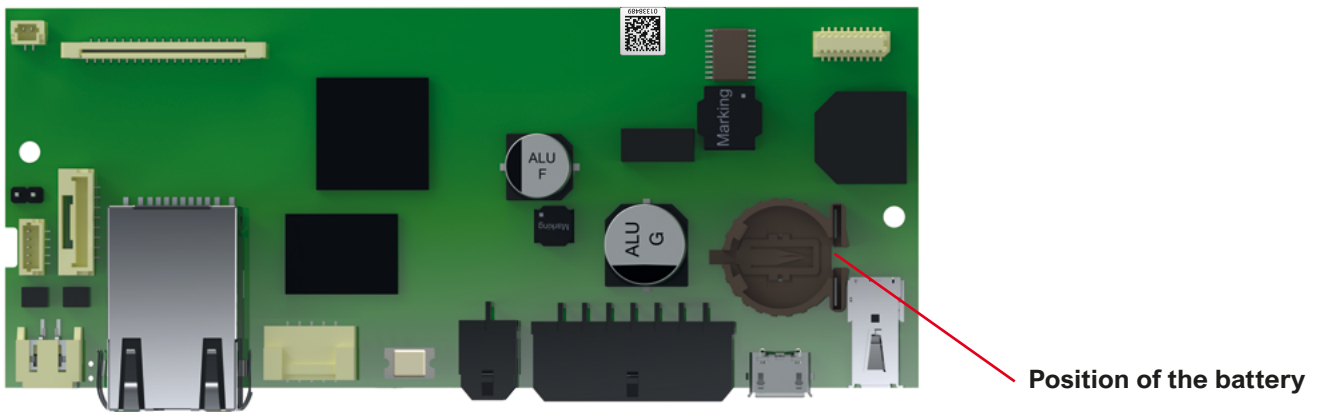

Annex A: Hardware Revision Information

This document is applicable for all products listed below. Please note that customized variants might possibly not support all features listed herein. Additional features are documented in specific attachments.

Platform	Article Number	Marking on PCB
NALLINO core S	900-4356R	0711 NALLINO V1.1
NALLINO core M	900-4341R	0711 NALLINO V1.1

Hardware Revision	Marking on PCB
V1.0	0711 NALLINO V1.1
V1.1	0711 NALLINO V1.1

Annex B: Assembly Options

B-1 Wi-Fi / Bluetooth

Some appliances require a wireless network connection. To be more flexible with regard to future Wi-Fi standards and regulations, we decided not to assemble this functionality directly onto the single-board-computer. We recommend an external USB or miniPCIe solution. Drivers for both versions will be included in the related operating systems. Please contact the support for information about supported modules.



Annex C: Guidelines and Standards

C-1 RoHS Declaration

Devices comply with the requirements of Directive 2011/65/EU of the European Parliament and of the Council of 8th June 2011 on the restriction of the use of certain hazardous substances in electrical and electronic equipment.

C-2 Supplier Declaration – Directive EG 1907/2006 REACH

SECO Northern Europe is manufacturer of electronic products, thus - in the sense of REACH - we are so called „downstream users“. The products we supply to you are solely non-chemical products (goods). Moreover and under normal and reasonably foreseeable circumstances of application, the goods supplied to you shall not release any substance. For that, SECO Northern Europe is neither obligatory for registration nor for the creation of material safety data sheet (MSDS).

From state of knowledge today our products contain no substances of very high concern from the current SVHC candidate list of the European Chemicals Agency in percentage >0,1.

We will immediately inform you in correspondence to REACH-Article 33 if any substance of content >0,1 percentage in our goods will be classified alarming by the ECHA. Based on the current status, however, we do not expect such an incidence.

C-3 UL Certification

Customers of SECO Northern Europe are attending on different markets. These markets are subjected to different UL certifications. Therefore SECO Northern Europe have no UL certification for their products.

To obtain UL certifications the product is designed to respect the following constraints:

- ▶ All electronic printed circuit boards are conform to UL standard
- ▶ Battery schematics meets the requirements of UL standard (please refer to chapter „**6.9 Battery Connector (X113)**“)
- ▶ All wirings are designed with UL components
- ▶ The selected components on the markets are UL (List of UL relevant components is available at SECO Northern Europe (on request))

SECO Northern Europe do not guarantee to obtain UL certifications.

C-4 SECO Northern Europe Conformity Statement

SECO Northern Europe GmbH develops and distributes reliable, Arm®-based embedded solutions. We offer various solutions from computer-on-modules (COM) to single-board computers (SBC) and fully-assembled human machine interface (HMI) with pre-installed operating system, display and housing.

These solutions are offered exclusively as OEM products. They do not include any application software that is intended for the end user. Therefore, we do not make any EU declarations of conformity in the name of SECO Northern Europe GmbH and do not provide the products with the CE mark.

Our customers provide the products with application software and build them into an end-user device as part of an industrial production process. They identify themselves as a manufacturer by affixing a license plate with their company or brand name.

We are happy to assist our customers when they compile the necessary technical documentation for the EU Declaration of Conformity of the complete device. We provide e.g. Supplier declarations or RoHS certifications, issue EMC testing results and carry out safety / radio / SAR tests, etc.

Annex D: Common Documentation

D-1 Warranty Hints



SECO Northern Europe embedded systems are subject to manufacturer's warranty as long as the products are handled with adequate care and caution and in accordance to this manual.

The period of guarantee starts from the date of shipment

The products are warranted against defects in material, quality and functionality within the warranty period.

During this period, the repair of the products is free of charge.

SECO Northern Europe will decide for repair or replacement at their own discretion.

If the product has been returned with or without prior notice and no failure or malfunction can be detected or the failure or malfunction is caused by inappropriate handling or the device has been returned after expiry of warranty period, SECO Northern Europe reserve the right to charge the user for repair or replacement.



The warranty does not cover defects caused by improper or inadequate installation, maintenance or handling by the user, unauthorized modification or misuse, operation outside the specification or non-compliance of this manual. In case of doubt, please contact the technical sales team prior to intended activity.

The warranty does also not cover any defects or damages of other equipment connected to the SECO Northern Europe product, faulty or not.

For warranty or repair service, please contact the technical sales team.

support.north@seco.com
rma.north@seco.com

D-2 Field of Application

The products covered by this document are designed and manufactured for the following applications (I). If you intend to use these products in applications as quoted in (II) we highly recommend a personal contact with our consultants and/or technical sales team.

(I) Recommended application areas for SECO Northern Europe embedded systems

Even for these applications, we recommend to get in contact with our technical sales team. We offer a wide range of support, even at an early stage of evaluation and/or design-in phase.

- ▶ Vending machines and gastronomy devices
- ▶ Industrial controllers and HMI systems
- ▶ Home automation and facility management
- ▶ Audiovisual equipment
- ▶ Instrumentation and measuring equipment

(II) Restricted application areas, prior consultation is mandatory to identify and meet the individual regulatory requirements

- ▶ Gas leak detectors
- ▶ Rescue and security equipment
- ▶ Safety devices
- ▶ Control and safety devices for airplanes, trains, automobiles and other transportation equipment
- ▶ Traffic control systems
- ▶ Control equipment for nuclear power industry
- ▶ Medical equipment related to life support etc.
- ▶ Gasoline stations and oil raffineries

Annex E: Technical Support

Before contacting the SECO Northern Europe support team, please try to help yourself by the means of this manual or any other documentation provided by SECO Northern Europe or the related websites.

If this does not help at all, please feel free to contact us.

Our technicians and engineers will be glad to support you. Please note that beyond the support hours included the Starter Kit, various support packages are available. To keep the pure product cost at a reasonable level, we have to charge support and consulting services per effort.

Shipping Address:

SECO Northern Europe GmbH
Schlachthofstrasse 20
21079 Hamburg
Germany

Support Contact:

Phone: +49 (0) 40 / 791 899-200

Fax: +49 (0) 40 / 791 899-39

E-Mail: support.north@seco.com

URL: north.seco.com

Annex F: General Information

Trademarks and service marks

Names and logos in this document may be trademarks of their respective companies.

In some cases descriptions for copyrighted products are not explicitly indicated as such. The absence of the trademark (™) and copyright (©) symbols does not imply that a product is not protected. Additionally, registered patents and trademarks are similarly not expressly indicated.

Drawings

All drawings, which are shown in this manual are schematic drawings.

For exact technical drawings please refer to our sales team or product manager

All other product or service names are the property of their respective owners.

All rights reserved. Products subject to technical changes, improvements and misprints.

© 2022 SECO Northern Europe GmbH